

EGC 2, EGC 4 Electronic Gas Carburetors

Air/Fuel Ratio Control and Improved Gas Mixing For Rich or Lean Burn Operation

- Fully automatic control
- Controls a variety of gaseous fuels
- Simple to install and use
- On-board diagnostics
- Direct support for wide-band oxygen sensors
- Can be used for rich- or lean-burn

Model EGC 2



Model EGC 4



AN INNOVATIVE APPROACH

The Electronic Gas Carburetor (EGC) offers an innovative and state-of-the-art approach to gaseous fuel carburetion for most gas engines in the range of 10 to 500 horsepower. It precisely controls the air/fuel ratio using variable pressure control combined with an advanced and improved mixing venturi. The EGC provides built-in control for a wide-band oxygen sensor that is located in the exhaust stream. This improved control technique and enhanced fuel mixing combine to provide the ultimate combination of reduced emissions along with improved engine fuel efficiency.

APPLICATIONS

EGC carburetors can be used in conjunction with a 2-way catalytic converter, and can be run in a Rich Burn (Stoichiometric) Mode to meet even the most stringent emission requirements. Because the EGC 2 is used with a wide-band oxygen sensor, the carburetor can also be used in a Lean Burn Mode (greater than 4% O₂ in the exhaust). Lean Burn can offer many advantages over Rich Burn control such as improved fuel economy, lower exhaust temperatures, and even reduced CO₂. In either Rich Burn or Lean Burn Mode, EGC carburetors will react quickly to load changes and other application-specific issues such as changing heating values in the gas supply. Whether you are trying to meet a new emission requirement, run your engine more efficiently, or just reduce engine maintenance and extend engine life, EGC carburetors will improve engine operation and efficiency for any application.

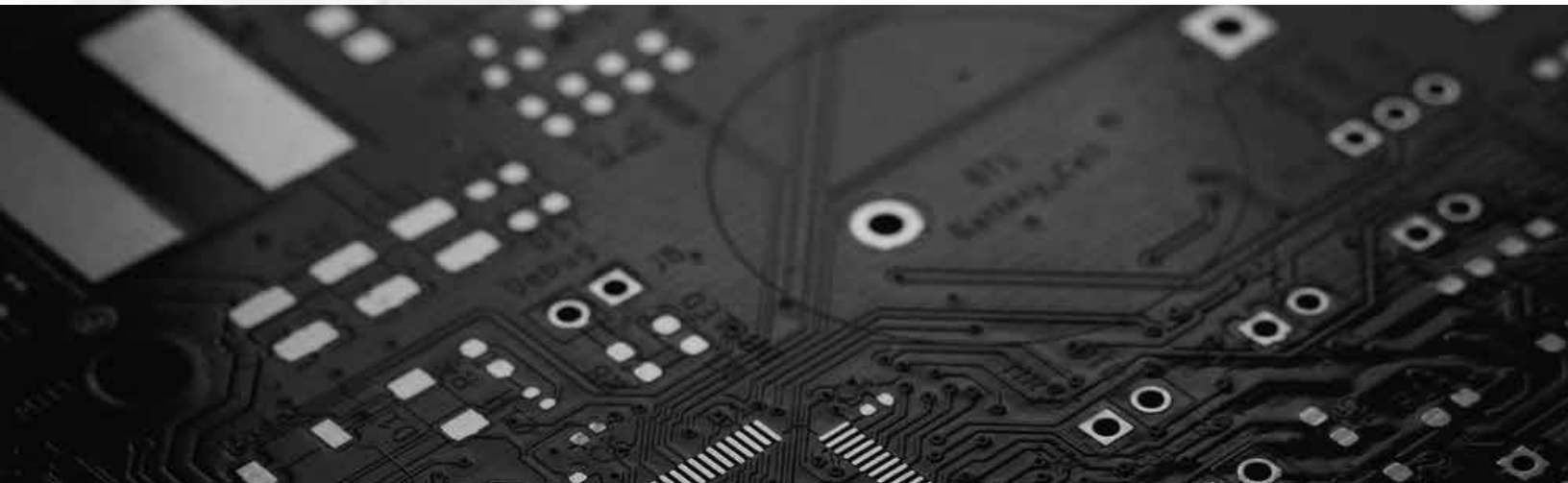

DESIGN FEATURES

INTEGRATED UNIT

The EGC is a single unit made to mount on the butterfly valve and will directly replace several popular carburetors. By combining the fuel pressure regulator, mixing venturi and fuel control valve, the installation is greatly simplified and the design and performance for each component is optimized for this application. This can also provide a cost savings over purchasing each component separately.

ELECTRONIC GAS CARBURETOR OPERATION

The EGC is an air/fuel ratio system designed specifically for small gas engines. It consists of two main components: the venturi mixer and the electronic pressure regulator working together to provide precise control of the air/fuel ratio in response to an oxygen sensor located in the exhaust. This patented technique provides superior control for gas engines.

VENTURI MIXER

The venturi shape of the mixer is designed to produce a low pressure at the throat of the venturi. This throat pressure is used to draw the fuel through the injection ports into the air stream. The injection ports and the venturi are designed to work together to provide the chemically correct air/fuel mixture at all load and speed conditions.

ELECTRONIC PRESSURE REGULATOR

A very precise pressure transducer is provided in the annulus surrounding the gas injection holes in the mixer. The pressure transducer measures the gas injection pressure. This signal is compared to a setpoint in the electronic system and a controller adjusts the pressure to match the setpoint. The fuel gas supply pressure should be large enough so that at maximum load the actuator in the EGC carburetor is open about 60%-70%.

The result is that when air flows through the mixer, a lower pressure is developed in the throat of the mixer which draws the correct amount of fuel into the air stream to provide the correct air/fuel ratio for stoichiometric operation. The air/fuel mixture is then trimmed by adjusting the set point of the electronic pressure regulator based on the oxygen content in the exhaust.

WHY THIS MORE ADVANCED SYSTEM

WORKS BETTER THAN OTHER SYSTEMS

Competing air/fuel ratio control systems work one of two ways:

The first is a method to control the pressure of the fuel gas injected into an existing carburetor. The characteristics of the existing carburetor require the pressure from the regulator to change when the load or speed of the engine changes to maintain a constant mixture. The oxygen content in the exhaust is the only indication that the injection pressure must change for the new load or speed. A transit period is required for the exhaust gas to travel through the engine, and the exhaust system to get to the oxygen sensor. This causes a dead time or delay in the O₂ feedback control signal. Because of this lag, the closed loop control system must operate with very low gains to maintain stable operation. This makes the system very slow responding to changes in load, speed or heating value of the gas. When a transient condition occurs, the engine will run out of compliance for a substantial time (15 minutes or more) following the transient.

The second method is to control a small by-pass valve that is used to add a small amount of fuel to supplement the main fuel flow. In this type of system, the pressure regulator is fixed at a constant pressure and the electronic control system adds fuel to the carburetor air inlet to make the mixture richer. This small valve is modulated to maintain the correct mixture. This kind of a system has the same problem as the first case, and has an additional problem of running out of adjustment range. Transient and load conditions cause the engine to run out of compliance.

The EGC maintains the gas injection pressure near zero for all conditions, so load changes do not require a re-setting of the pressure control. Therefore, the engine does not go out of compliance during a load transient, or if the pressure setpoint does need to change slightly, it will come right back in when the oxygen sensor feedback signal indicates the error.



RICH BURN CONTROL

In Rich Burn Mode, EGC products will maintain the fuel mixture very near stoichiometric. When combined with a 3-way catalyst, emissions can be maintained below 0.1g/hphr. The lower the level of desired emissions, the more critical fast and accurate air/fuel ratio control becomes.

RUNNING IN RICH BURN MODE ALLOWS MAXIMUM HORSEPOWER OPERATION

All EGC products have optional Electronic Governors. These governors will directly drive a third part actuator or electronic throttle body to control the speed of the engine. The integrated governor does offer improved gain adjustment and control over separate and individual governors, and air fuel ratio controllers.

Running in a Rich Burn Mode the EGC 2 will work with engines from 10 hp to about 250 hp.

- **Lowest possible emissions**
- **Single unit replaces several components**
- **Engine can run at rated horsepower**
- **Optional electronic governor speed control**
- **Fast and accurate control**

The EGC 4 is designed for engines from 250 hp to 500 hp (or up to approximately 1000 hp with dual EGC 4's).



LEAN BURN CONTROL

- No catalyst required to meet basic EPA emissions requirements
- Carburetor offers improved mixing and extends the lean limit
- Improved fuel economy
- Reduced exhaust temperature
- Controls a variety of gaseous fuels

LEAN BURN APPLICATIONS

In many locations in the US and other countries, the emissions requirements are at or above 1g/bhphr. In these locations, lean combustion may be appropriate. Under lean combustion conditions, the engine is operated with a very lean air/fuel ratio, whenever excess air is available for combustion. The excess air passes through the engine and the oxygen is not all consumed in the combustion process. The extra air carries the heat away and the combustion takes place at cooler temperature. NO_x is formed as a function of high gas temperature. By reducing the temperature of the flame and resulting gas temperature in the cylinders, NO_x is dramatically reduced.

On most gas engines, 30% to 35% excess air will yield emissions less than 2g/bhphr of NO_x and very low CO. In order to operate in the Lean Burn Mode, the following conditions must exist:

- The engine must be capable of generating excess combustion air.
- The ignition must be capable of igniting a lean mixture.
- The carburetor can be set to run the engine lean. That is to say, there will be unburned oxygen in the exhaust. Normally, engines running greater than 4% oxygen in the exhaust are considered to be running lean. The excess oxygen is the result of excess air in the air/fuel mixture at the intake of the engine.

BENEFITS OF OPERATING IN LEAN BURN MODE

All EGC products have optional Electronic Governors. These governors will directly drive a third party actuator or electronic throttle body to control the speed of the engine. The integrated governor does offer improved gain adjustment and control over separate and individual governors, and air fuel ratio controllers.

- The engine runs much cooler than it would in Rich Burn Mode, extending the life of the engine and reducing the maintenance of the engine.
- The fuel efficiency is improved dramatically.
- Running lean reduces emissions without the addition of a catalyst. Generally requirements of 1 to 2g/hphr can be met without the addition of any after-treatment.

LEAN BURN CONTROL ISSUES

Lean Burn Mode operation may involve a small reduction in horsepower. In many applications the engine is over-rated for the application and this reduction is not evident because the overhead was enough to cover the additional required horsepower.

While emissions reduction in Lean Burn Mode is significant even without a catalyst, it will not be possible to achieve the same level of emissions reduction as is possible for Rich Burn control with a catalyst.

If further reductions of NO_x are required, it is possible to run the EGC in conjunction with an SCR to obtain very low emissions numbers.



SPECIFICATIONS

FUEL TYPES

The EGC can be used with hydrocarbon fuel in a gaseous state, including:

- Natural Gas
- Propane
- Digester biogas
- Trash gas from oil wells

HEATING VALUE OF THE FUEL

If the heating value of the fuel changes while the engine is running under the control of the oxygen sensor control, the EGC will automatically adjust the injection pressure to maintain the mixture and the low emissions.

POWER REQUIREMENTS: 10 VDC to 14 VDC

12 VOLT BATTERY: 3.0 amp at 10 volts with 6 amp peak

DESIRED FUEL SUPPLY PRESSURE: 4-8 inches of water (This pressure will be greater for the EGC 4 and will be application-specific.)

FULL AUTHORITY VALVE

The EGC controls all of the fuel to the engine which will allow for greater range of load or changes in heating value than can be provided by smaller by pass type valves.

FULLY AUTOMATIC

Starts the engine with a default pressure setting. When the O₂ sensor is determined to be operating properly, it automatically will adjust the pressure set point to minimize the emissions.

DATA COMMUNICATIONS

Data is available serially through Mod Bus or CAN Bus interface. By communicating all measured parameters and logged faults, the EGC 2 becomes integral to the complete engine-system On Board Diagnostic solution.

APPLICATIONS:

- Gas Compression
- Power Generation
- Irrigation Pumps
- Refrigeration

STANDARD AFM GAUGE

The AFM gauge normally displays either air/fuel ratio or lambda. It also assists with free air calibration of the oxygen sensor.

OPTIONAL DISPLAY

The EGC display can be configured to meet most local air board requirements such as:

- Monitor Pre- and Post-Catalyst Temperature
- Visual and/or Audible Alarm for Upset Condition
- Variable Set Point based on Load Signal
- Monitoring of O₂ Setpoint and Feedback
- Monitoring of Control Pressure
- Gain Adjustments

CONFIGURATION SOFTWARE

The EGC can be configured and monitored using a personal computer via serial communications. Valve Viewer (EGC) provides a graphical user interface to adjust and record variables and setpoints including the O₂ sensor setpoint and default pressure control as well as all tunables in the EGC. This configuration software is also excellent for data logging the feedback from the Oxygen Sensor, Pressure Transducer, and the integrated Electrical Actuator.

EMISSIONS REQUIREMENTS

The emissions limits set by government agencies are quite different, depending on the State and County. The EGC will provide the best available control technology (BACT) when used in conjunction with a properly sized 3-way catalytic converter, to meet even the most stringent emissions requirements anywhere.



EGC 2/EGC 4 DIMENSIONS

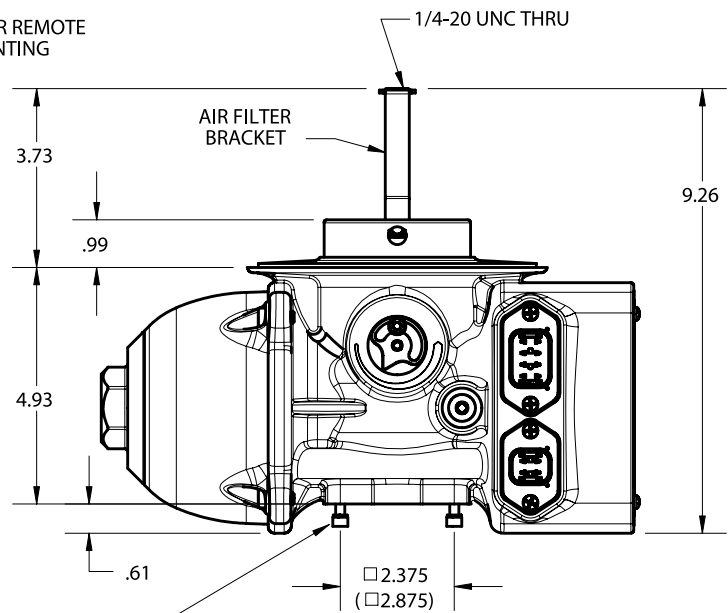
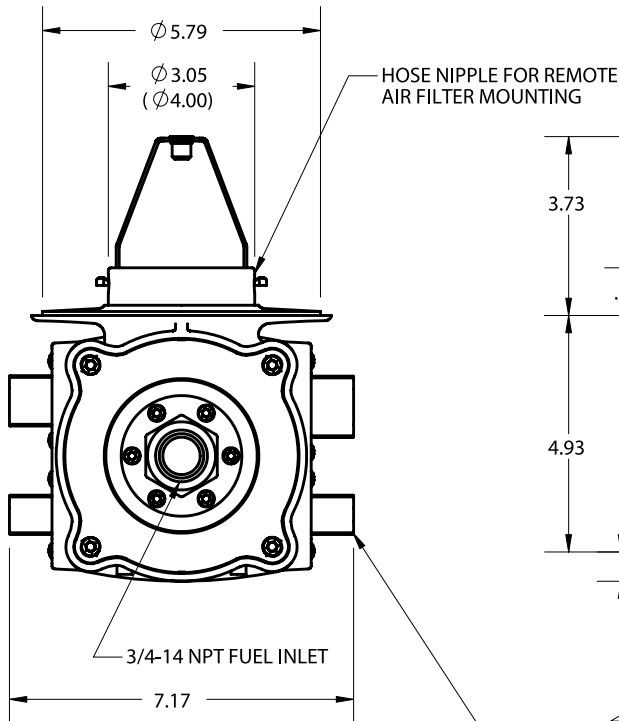
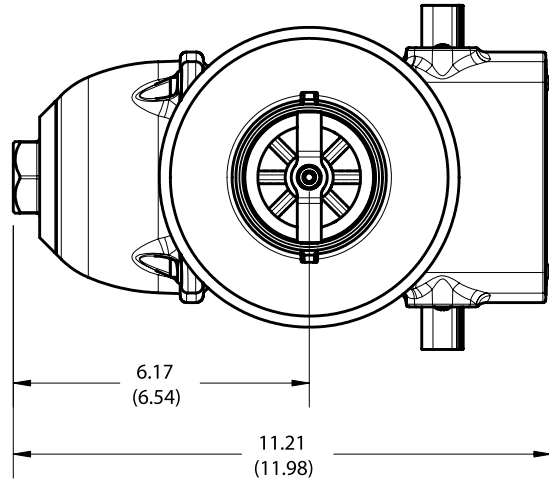
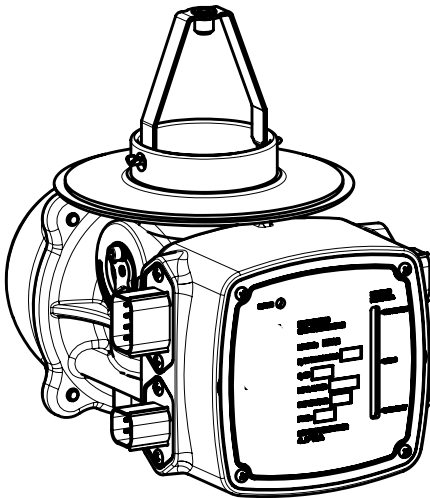

4EA ELECTRICAL CONNECTORS
SEE INSTALLATION MANUAL FOR DETAILS

BOLT PATTERN FOR IMPCO 200 THROTTLE BODY
10-24 UNC x .41 DP, 4PL LOCATED ON 2-3/8 SQUARE PATTERN
(BOLT PATTERN FOR IMPCO 400/425 THROTTLE BODY)
(5/16-18 UNC x .50 DP, 4PL LOCATED ON 2-7/8 SQUARE PATTERN)

DIMENSIONS SPECIFIC TO THE EGC4 ARE SHOWN IN PARENTHESIS (X.XXX)
ALL OTHER DIMENSIONS ARE THE SAME FOR THE EGC2 & EGC4 UNLESS OTHERWISE NOTED

ALTRONIC

A Member of the HOERBIGER Group

712 Trumbull Avenue / Girard, Ohio 44420
(330) 545-9768 / Fax: (330) 545-9005
www.altronic-llc.com Email: sales@altronic-llc.com

FORM EGV2-EGV4 8-22 ©2022 Altronic, LLC

