

ALTRONIC V

Ignition System for 1-6 Cylinder Engines

- Eliminates magneto, breaker points and impulse coupling
- Capacitor discharge electronic ignition
- Alternator unit with self-contained timing and distribution
- Extended spark plug life
- Superior ignition performance
- Easy to service – plug-in modules and removable back cover
- CSA-certified for Class I, Division 2, Group D hazardous areas

Altronic V is a self-powered, low-tension, capacitor discharge ignition system for 1 to 6 cylinder, 2 or 4-cycle engines. The Altronic V unit can be furnished with any number of output channels between 1 and 6. For 4-cycle applications, a choice is offered of units using the exhaust stroke firing principle or units firing on the compression stroke only. Altronic V has internal timing pick-up coils combined with Altronic's proven 8-pole permanent magnet alternator to give high output at low engine cranking speeds. The electronic circuit has a minimum of components for maximum reliability, and all are mounted on the unit's removable back cover for ease of service.

The combination alternator/timing-distribution unit design allows for a simple installation, directly replacing high and low-tension, breaker-type magnetos. A wiring harness and one ignition coil per cylinder complete the system.

Options available for the Altronic V ignition system include long spark duration coils and electronic timing capability to allow the user to customize the system to his particular application requirements.



CERTIFIED
CLASS I, DIV 2
GROUP D

Factory
Mutual
System
APPROVED

Superior Performance

Altronic has been at the forefront of ignition technology leadership. The Altronic V continues in this tradition by providing a total performance unequalled in its class. Compare the operating parameters listed below with any other system. Of all ignition performance factors, the delivered spark duration at a typical engine KV on demand is most important for smooth, consistent engine performance. Altronic V's standard coil gives comparable spark duration to other manufacturer's long duration coils. Altronic's long duration coil, 591010, provides the extended duration required for lean mixture or non-standard fuel applications.

IGNITION COIL	MAX. KV OPEN CIRCUIT	SPARK DURATION AT 10KV
Standard - 501061	34KV	180 usec
Long Duration - 591010	34KV	450 usec
Integral - 591007	28KV	150 usec

Low Maintenance Design and Ease of Service

Altronic V has been designed to be as maintenance free as possible. Thousands of Altronic V units in successful field operations since 1981 have resulted in a design evolution to the present field proven form. The internal gears are large and underloaded. When service is required, Altronic V is designed to make it easy. All electronic components are mounted on the back cover assembly which is easily removed from the alternator section of the unit.

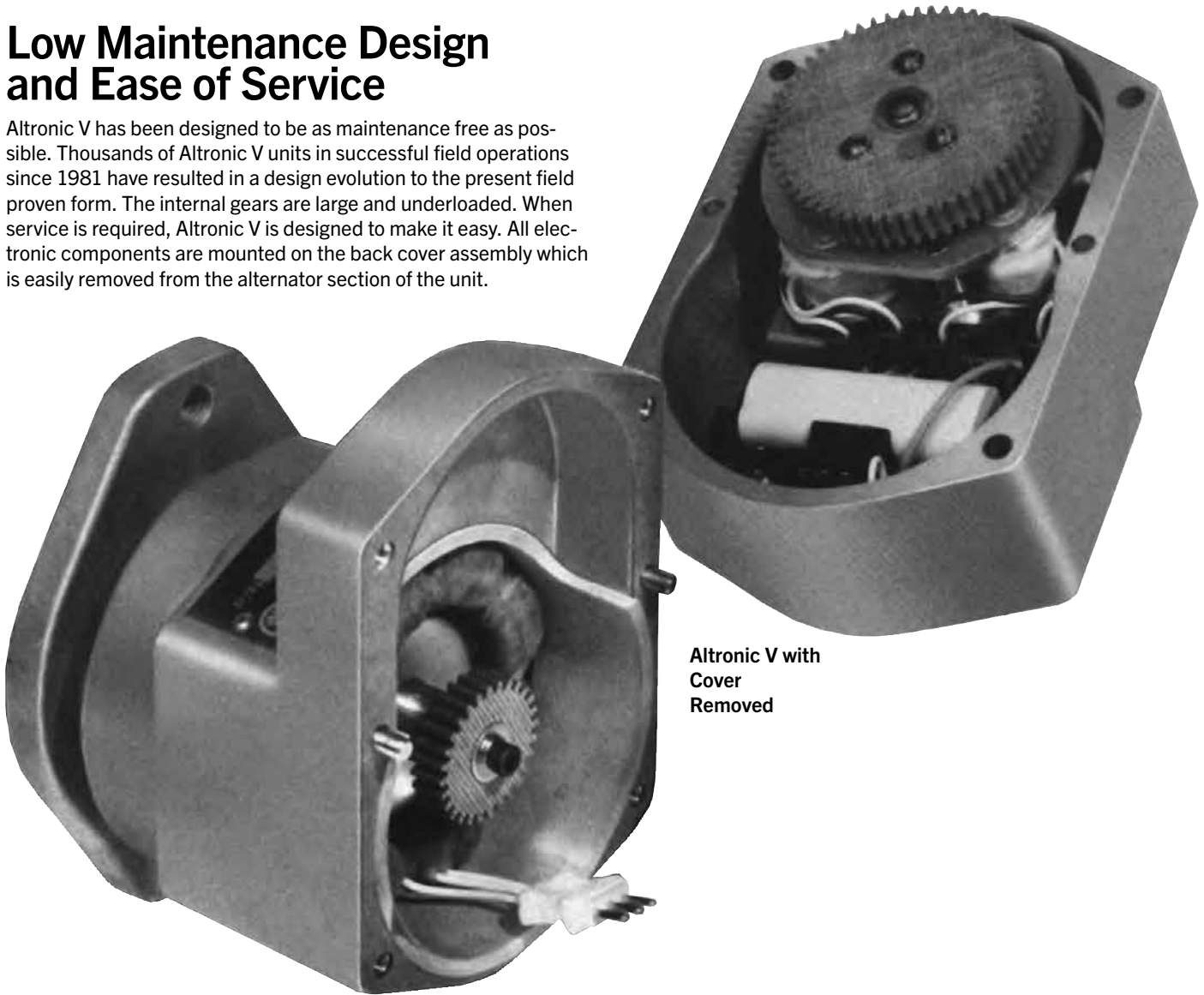

Altronic V with Cover Removed



Ease of Installation

Altronic V is internally timed and very compact, allowing ease of installation on virtually any industrial engine with a magneto drive. Altronic V is available in a choice of mounting flanges and engine drive ratios. This gives engine users and manufacturers wide flexibility in applying the system. Available options are designated in the charts below.

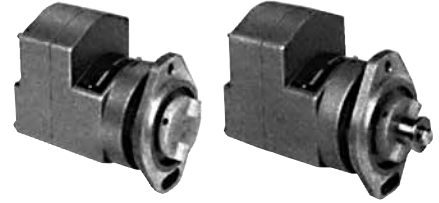

NUMBER OF CYLINDERS	2-CYCLE DRIVE RATIOS*	4-CYCLE DRIVE RATIOS*
1	1:1, 2:1, 3:1	0.5:1, 1:1, 1.5:1
2	1:1, 2:1, 3:1	0.5:1, 1:1, 1.5:1
3	2:1, 3:1	1:1, 1.5:1
4	2:1, 3:1	1:1, 1.5:1
5	—	1:1, 1.5:1
6	—	1:1, 1.5:1

MOUNTING FLANGE	STANDARD SHAFT COUPLING DRIVEN	EXTENDED SHAFT GEAR DRIVEN
1 slot, 3.250" pilot	-A	-AW
2 slots, 3.250" pilot	-GV	-GVW
1 slot, 3.000" pilot	-D	—

* Altronic V RPM: Engine RPM

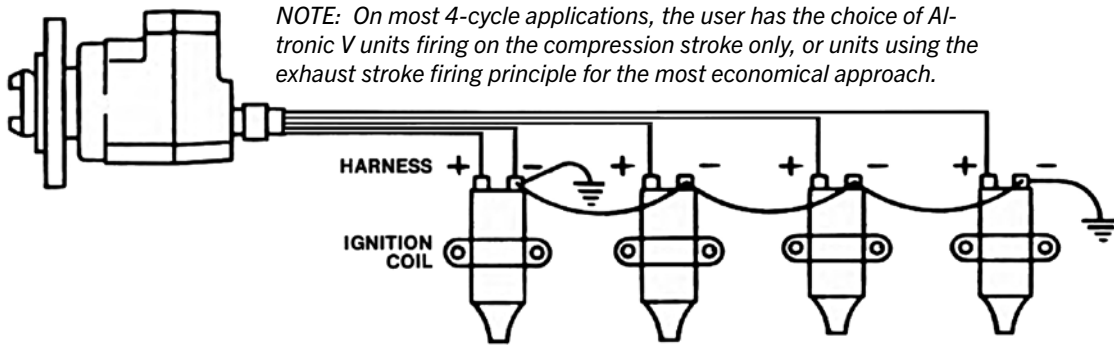

NOTE: On most 4-cycle applications, the user has the choice of Altronic V units firing on the compression stroke only, or units using the exhaust stroke firing principle for the most economical approach.



Altronic V with Timing Unit

Electronic Timing Capability

A key element for the future is the ability to control timing electronically in order to optimize engine performance under various operating conditions. Altronic V has been designed with this requirement in mind, offering an adjustment range of up to 25 engine degrees. The 581603 timing unit pictured here is designed for a dual-gas or dual-load application requiring two different ignition timing settings. The adjustment screw is used to set the desired differential.

Altronic Ignition Coils

Altronic ignition coils cover all application requirements, unshielded or shielded. The standard coils are recommended for most applications; where lean fuel mixture or low-BTU gas is encountered, the long spark duration versions are available.

UNSHIELDED COILS

501061 – Standard
591010 – Long Duration



501061-S
SHIELDED COIL
Standard

591010-S
SHIELDED COIL
Long-duration



591007 INTEGRAL COIL
1"-20 thread, 5.6" length



Accessories



DTHO-1201/DTHO-3201
UNIVERSAL DIGITAL
TACHOMETERS

Includes integral overspeed trip and hourmeter. Precise digital readout, ± 1 RPM accuracy. Operates from Altronic V ignition—no other signal required.

Applications

AJAX
ALLIS CHALMERS
ARIEL
CATERPILLAR
CONTINENTAL
CUMMINS
DEUTZ
DORMAN
INTERNATIONAL HARVESTER
LUFKIN
MINNEAPOLIS MOLINE
OILWELL
WAUKESHA
WHITE

ALTRONIC

A Member of the HOERBIGER Group

712 Trumbull Avenue / Girard, Ohio 44420
(330) 545-9768 / Fax: (330) 545-9005
www.altronic-llc.com Email: sales@altronic-llc.com

FORM ALT V 8-22 ©2022 Altronic, LLC