

**CAUTION:** The DPS-1591DP digital/bar-graph pressure gauge is suitable for use in Class I, Group D, Division 1 and 2 hazardous locations when installed in accordance with these instructions.

**WARNING: DEVIATION FROM THESE INSTALLATION INSTRUCTIONS MAY LEAD TO IMPROPER OPERATION OF THE MONITORED MACHINE WHICH COULD CAUSE PERSONAL INJURY TO OPERATORS OR OTHER NEARBY PERSONNEL.**

## **1.0 DESCRIPTION**

- 1.1 The Altronic DPS-1591DP digital pressure gauge is a loop powered electronic instrument designed for applications needing high accuracy, excellent long-term stability, trouble-free operation, high performance and long life. No separate power supply is needed; the DPS-1591DP gauge takes power directly from the current loop. It incorporates a large 0.75" four digit, 25 bar LCD display with a four key sealed membrane switch.
- 1.2 The integral pressure transducer is a high quality, all stainless steel media-isolated sensor with no internal "O" rings, no silicone oil and no welds. The gauge is intended for use in the measurement of gases and liquids compatible with stainless steel.
- 1.3 The accuracy of the gauge is +/- 0.25% of full scale over a temperature of 0EC to 55EC (32EF to 131EF). Full operating temperature is -40EC to 85EC (-40EF to 185EF).
- 1.4 The gauge is ideally suited to process applications with features such as an adjustable software filter to stabilize readings where the pressure is fluctuating. The pressure units are selectable and are displayed on the LCD. When a new unit is selected, the gauge automatically converts the reading to match the units. A configurable bargraph gives the user a quick visual indication as to where the pressure is relative to min and max values and whether it is increasing or decreasing. A maximum high and maximum low pressure reading detection shows the operator the pressure extremes that the process was exposed to. In addition, the input pressure is continuously compared against two adjustable setpoints that can be adjusted using the front keypad on the gauge. The 4-20 mA loop can be configured anywhere within the range of the gauge, as well as reverse acting. The gauge uses the loop current as its primary power. With the absence of loop current it automatically switches to the internal "C" size 3.6 volt replaceable lithium cell. It continues to operate as a battery-powered gauge until loop power returns. The gauge is designed with the latest microcontroller technology for extremely long battery life. To extend battery life even longer, a programmable power-on timer can be set from 0 to 720 minutes.
- 1.5 The enclosure is a standard 4-1/2" ABS case with a special swivel fitting and moveable flange. The gauge can be changed to front or back flange and bottom or back mount in the field with no more than a screwdriver.

## **2.0 MOUNTING**

- 2.1 Mount the gauge inside a control panel or to a suitable flat surface so that the display is at a convenient viewing height using the flange and hardware supplied. A drilling template is provided. NOTE: Avoid mounting the gauge with the LCD display facing direct sunlight. The display temperature range is -40EF to +185EF (-40EC to +85EC). Although flange mounting is suggested for high vibration applications, the flange does not have to be used to mount the gauge, mounting the gauge using its pressure fitting in a pipe is acceptable as long as excessive vibration is not experienced.
- 2.2 The pressure fitting is stainless steel 1/4" male NPT. Attach the gauge to the pressure fitting using teflon tape or equivalent. Tighten the pressure fitting by hand and continue to tighten 2 to 3 turns using a 9/16" wrench on the stem of the gauge. Do not use the gauge case to tighten pressure fitting.

**WARNING: SEVERE INJURY OR DAMAGE CAN OCCUR THROUGH IMPROPER USE OF PRESSURE INSTRUMENTS.** Do not exceed recommended pressure limits of transducer, tubing and fittings. Be certain all pressure connections are secured.

**CAUTION: THIS GAUGE CAN DISPLAY ZERO PRESSURE EVEN WITH UP TO 20% OF FULL SCALE PRESSURE APPLIED.** Do not rely on the display indication when disconnecting pressure - it may not be indicating true pressure.

## **3.0 WIRING (SEE WIRING DIAGRAMS)**

- 3.1 LOOP WIRING - The DPS-1591DP digital pressure gauge is designed to transmit analog 4 to 20mA signals over an industry standard 2-wire current loop for the control of valves, actuators, and other devices commonly used in process control. The gauge also is powered directly from the two wires of the current loop. Connect the loop wires to terminals 1(+) and 2(-); power requirement is 10 to 32 Vdc, 24 Vdc nominal. See wiring diagram figure 3. The loop is protected against open and short circuits and reverse wiring. The maximum load resistance that can be tolerated in the loop is determined by the supply voltage, but should not exceed 1000 ohms. See figure 4 for the maximum load resistor vs. the supply voltage.

### NOTES:

1. A 250 ohm loop resistor can be used over the supply voltage range from 14 to 32 Vdc.
2. At 12 Vdc supply voltage, the maximum loop resistor for 20 mA loop output current is 150 ohms.
3. If using a 500 ohm loop resistor and a desired full scale loop output of 20 mA, the supply voltage must be between 17 and 32 Vdc.

- 3.2 OUTPUT SWITCH WIRING - There are two user-programmable output switches that can be set anywhere within the range of the gauge. A fault condition will cause one or both of the output switches to turn ON/OFF to their common. These switches are solid state, open drain FET's and are isolated from the loop supply. The common is also isolated from the loop supply thus allowing for low-side or high-side switching. The switches are rated at 100 Vdc., 1.0 Amp continuous. Please refer to the wiring diagram figures 6 and 7.
- 3.3 HAZARDOUS AREA OPERATION - The DPS-1591DP gauge is CSA-certified for CLASS I, DIVISION 2, GROUPS C & D areas when mounted in a suitable enclosure. The device may be operated as CLASS I, DIVISION 1, GROUPS C & D intrinsically safe, if the following conditions are met:
- A. The gauge is powered from a CSA-certified zener barrier rated 30 volts max., 120 ohms min. A suitable barrier is a Stahl part no. 9002/12-280-110-00; follow the installation instructions supplied with the barrier.
  - B. The switch outputs, if used, are connected to the sensor inputs of an Altronic DA or DD annunciator system with the 690 series power supply.
- In addition, the following requirements must be met (see NFPA standard no. 493):
- 1. The intrinsically-safe gauge wires within the panel enclosure must be kept at least two (2) inches away from other wiring.
  - 2. Wiring to valves, actuators and other control devices must have a grade of insulation capable of withstanding an AC voltage of 500 volts RMS.
  - 3. Control wires must be run in separate conduits and junction boxes from high voltage wires such as Ignition, fuel valve, and other high voltage wiring.

<p><b>WARNING: SUBSTITUTION OF COMPONENTS MAY IMPAIR INTRINSIC SAFETY AND/OR SUITABILITY FOR CLASS I, DIV. 2.</b></p> <p><b>DO NOT DISCONNECT EQUIPMENT IN DIV. 2 ENVIRONMENT UNLESS POWER IS SWITCHED OFF OR THE AREA IS KNOWN TO BE NON-HAZARDOUS.</b></p>
--

#### **4.0 NORMAL OPERATION**

- 4.1 The DPS-1591DP digital pressure gauge is shipped with the internal battery installed so that it can easily be configured on the bench. Press any key and the gauge will power-up. A complete LCD segment test is performed followed by the full scale reading of the gauge in psi units. The display update time is 4 updates per second with loop power and 1 update per second when operating on battery power. The gauge may be adjusted to local atmospheric condition using the ZERO/TARE function (see ZERO/TARE section below). The full scale reading of the gauge in psi units can be displayed at any time by pressing both arrow keys (• and -) together.
- 4.2 The DPG gauge measures "gauge" pressure. "Gauge" pressure measures the input pressure referenced to ambient atmospheric pressure. The gauge will also read vacuum down to absolute zero. The vacuum readings will be displayed as minus in the chosen unit of measure.

- 4.3 ZERO / TARE - The zero function is used to “zero” the gauge to compensate for any ambient effects that cause an offset at zero pressure. The zero offset is limited to +/-2 psi to +/-10 psi depending on the range of the gauge. To “zero” the gauge, vent the pressure to the gauge to atmosphere (0 psig); press the SETUP key, the gauge will read “ZER0”, press ENTER and the gauge will be zeroed at the current pressure value.

The tare function can be used to offset the zero point of the gauge to any vacuum or positive gauge pressure from 0 to 20% of full range of the gauge. Both the under and over arrows will blink to indicate when tare is used. To access the tare function, press the SETUP key until the display reads “tare”, press ENTER and the gauge will be zeroed at the current pressure value. The tare offset can be canceled at any time by pressing SETUP and then the up or down arrow key then ENTER. The zero offset will return to the original zero reading. Note that offsetting the zero using the tare function can limit the range of the gauge. Using a 0-100 psi gauge as an example, if the tare function is exercised at 20 psi reading, the maximum pressure that can be displayed will be 110% of actual full scale (110 psi minus 20 psi offset = 90 psi displayed).

CAUTION: Before disconnecting the gauge from its pressure source make sure that the pressure is at zero psi by canceling the tare function as described above.

- 4.4 OVER PRESSURE CONDITIONS - The DPS-1591DP gauge has a displayed range of -14.7 psig (or equivalent) to 110% of gauge range. If these limits are exceeded, the low or high out of range arrows will be displayed and the reading will remain at the limit indicated above. Note: If tare was used to offset zero the max reading will be offset by the zero offset amount. For an explanation, see ZERO / TARE section above.

IMPORTANT: The internal pressure transducer in the gauge will withstand a maximum of 2 times the rated pressure without damage; burst pressure is 5 times rating or 25,000 psi, whichever is less. If the overload rating is exceeded, failure may occur. Pressure fluctuations may not be displayed, especially if the filter value is set for high dampening. Pressure fluctuations occur in most systems; select the gauge range with a rating high enough to prevent overload by peak pressures of pulsations. It is recommended that a pressure snubber be used which will reduce the peak pressure applied to the gauge. The life of the gauge will be extended with the use of a snubber or pulsation dampener.

- 4.5 SELECTING UNITS - A number of pressure units are available with the DPS-1591DP gauge; the most common ones are displayed on the LCD. To select a different unit press the SETUP key until the display reads “Unit”, press the ENTER key and use the • or - (up or down) arrow key to scroll through the displayed available units. To configure the gauge for pressure units that are not on the display, select “SPEC” (special) and press ENTER. Using the flowchart on page 11 as a guide, configure the decimal point location and the low and high values. The low value will be the pressure value in the chosen units equivalent to -14.7 psig, and the high value will be the pressure value in the chosen units at 110% of gauge range. Note: The zero and tare offsets are not adjustable when using the “special” configuration.

- 4.6 MEASURING VACUUM - All ranges of the DPS-1591DP gauge can measure vacuum down to -14.7 psig or equivalent in another unit of measure. When measuring a pressure less than ambient barometric conditions, a minus (-) sign will be displayed. If the input goes below -14.7 psig, the display will read -14.7 (or equivalent) and the lower out of range arrow will be displayed. Note: The accuracy for readings below 0 psi is +/-2% of highest vacuum reading.

- 4.7 ADJUSTING THE DISPLAY FILTER - The display filter can be used to stabilize the display reading of a pulsating pressure input. The filter value is read out from 1 to 255; 1 being minimum filter value, 255 being maximum filter value. Below are some typical filter values and their effect on the display reading. Settling values are approximate times in seconds to reach 90% of new reading. To set the filter value press the SETUP key until the display reads "FILT". The display will read the previously set filter value. Use the • or – arrow key to increase or decrease the filter value and press ENTER to save the new filter value. Note: The filter values listed are when the gauge is powered from loop power, when operating from internal battery power the filter times will be approximately 7 times longer.

FILTER VALUE	1	64	128	200	210	220	230	240	245	247	253	255
SETTLING, SEC.	.5	1	1.3	1.5	1.8	2.3	3	5	8.5	11	30	90

- 4.8 HI / LO DETECTION - The DPS-1591DP gauge continuously records the minimum and maximum filtered pressure applied to the gauge. To view the max and min values, press the SETUP key until the display reads "HI.LO" and press ENTER. The display will read the minimum low value recorded. Press ENTER to read the maximum high value recorded. The lower half of the bargraph will display to indicate the reading is the min low value and the upper half of the bargraph will display to indicate the reading is the max high value. These readings will remain stored if the gauge is powered down.
- 4.9 RESETTING RECORDED HI / LO VALUES - To clear the current values, display either the low or high max value and press either the • or – arrow key; the display will show "Clrd" and the values will begin new max low and high values.
- 4.10 CONFIGURING THE BARGRAPH - The bargraph shows the gauge pressure in a graph form between two points. The bargraph can be configured to display pressure in different modes. To reach the bargraph menu, press the SETUP key until the display reads "bAr", the previous configuration will be displayed. To change the type of bargraph, press either the • or – arrow key to scroll between the different configurations.

- "On IIIIII" Bar mode between the two max points. When this mode is selected the low point will be 0 psig or equivalent units and the bars will increase to 100% of range.
- "On I I I" Single bar between the two max points. When this mode is selected the low point will be 0 psig or equivalent units and a single bar will increase to 100% of range.
- "On.HL IIIIII" Bar mode between two selected points. When this mode is selected press ENTER and adjust the low point to the desired value. Press ENTER and adjust the high point. The bars will increase from the low point to the high point.
- "On.HL I I I" Single bar between two selected points. When this mode is selected press ENTER and adjust the low point to the desired value. Press ENTER and adjust the high point. A single bar will increase from the low point to the high point.
- "OFF" No bargraph displayed. When selected the bargraph will be off.

- 4.11 CURRENT LOOP - The 4-20mA current loop allows the user to output a signal proportional to the pressure being measured and displayed. The nominal range is 4mA to 20mA; the maximum range is 3mA to 25mA. To configure the current loop, press the SETUP key until the display reads "LOOP" and press ENTER. The display will read the value for the previously set 4 mA pressure point in the previously selected units. Use the • or – arrow key to increase or decrease the numeric value for the 4 mA point. Press ENTER and the numeric value for the 20 mA point will be displayed. Again use the • or – arrow key to adjust the desired 20 mA numeric value. Press ENTER to save the new 4-20 mA configuration and return to the normal reading. Loop accuracy is +/-0.25% of full scale. NOTE: The 4-20 mA current loop can be configured for reverse action. Simply configure the 4mA point with a higher pressure than the 20 mA value and visa-versa.

## **5.0 ADJUSTING AND CONFIGURING SETPOINTS**

- 5.1 GENERAL - There are two individually adjustable and configurable setpoints which can be set anywhere within the range of the gauge. Note: The display and setpoints will remain active with the loss of loop power (they will be kept active by the internal battery). However if both setpoints are not used (set to "OFF"), and the power-on-timer is set to something other than zero and it expires, the gauge will go into power down mode to extend battery life until a key is pressed or loop power returns. To view or configure the setpoints, press the SETUP key until the display reads "SP.1" or "SP.2" and press the ENTER key. The configuration menus follow in sections 5.2 through 5.6.
- 5.2 LOW, HIGH, LOOP, OFF - Each switch can individually be set to trip on a high pressure, a low pressure, on loss of loop or off. The display will read either "LO", "HI", "LOOP" or "OFF"; use the • or – arrow key to make a selection and press ENTER. If set for "HI", the switch will change states on increasing pressure at the setpoint value. If set for "LO", the switch will change states on decreasing pressure at the setpoint value. If set for "LOOP", the switch will change states on the loss of the 4-20 mA loop voltage/current. If set for "OFF" the switch will be set to off or open and will not change states. When set to off, no further setpoint configurations will be displayed; the display will show "SAVE/donE" and return to the normal display screen.
- 5.3 SETPOINT INDICATION - When the setpoint indication is set to "On" and a setpoint is tripped, the display reading will alternate between the pressure reading and a setpoint label. The setpoint labels are LO.1, LO.2, HI.1, HI.2, LP.1, and LP.2. If the setpoint indication is set to "OFF" and a setpoint is tripped, the display will continuously read the input pressure. Each setpoint can be individually configured to either show an indication or not. Use the • or – arrow key to select "On" or "OFF" and press ENTER to save.
- 5.4 NORMALLY OPEN OR NORMALLY CLOSED - Each switch can be set to normally open "nO" or normally closed "nC" for the normal or safe state. For example, if set for normally open and a high setpoint, the switch will be open below the pressure setpoint and close upon increasing pressure at the setpoint value. Use the • or – arrow key to select normally open "nO" or normally closed "nC" and press ENTER to save.

- 5.5 **ADJUSTING SETPOINTS** - With the setpoint value displayed, press the • or – arrow key to increase or decrease the value until the desired trip point for that switch is reached. Press ENTER to accept the new value. The new setpoint value will be saved to nonvolatile memory at the end of the setpoint menu when the ENTER key is pressed and the display shows “SAVE/donE”. Pressing SETUP while in this menu will cause the display to return to the normal screen with no changes taking effect.

NOTE: When adjusting the setpoints, the previous setpoint values are monitored, and the new value is monitored only at the end of the setpoint menu when the ENTER key is pressed and the display reads SAVE/donE. If no key is pressed for 15 seconds, the display will return to the normal mode and the configuration will revert back to the previous parameters.

- 5.6 **HYSTERESIS** - Hysteresis sometimes is referred to as a deadband value. It is the numeric value above the low setpoint value that the switch will clear, and below the high setpoint value that the switch will clear. The hysteresis value is displayed in absolute pressure units that the gauge is configured for. For example, if a 90 psi high setpoint with a 10 psi hysteresis is desired (80 psi release point), set the “HySt” value at 10 psi. The hysteresis can be individually set for each switch. Press ENTER and the display will show "HySt" for one second and then display the previously set hysteresis value. Use the • or – arrow key to increase or decrease the hysteresis value and then press ENTER to save the new value. The hysteresis value range for a low setpoint is from the setpoint value up to 110% of full scale, and for a high setpoint, from the setpoint value to absolute zero pressure units. NOTE: If the hysteresis value is set so that it cannot be cleared easily by gauge pressure change, the setpoint can be cleared manually by going to the setpoint menu and turning the setpoint off. Make sure the gauge pressure is below the high setpoint or above the low setpoint and go back into the setpoint menu and turn the setpoint on again. Setting a large hysteresis value will in effect act like latching outputs.

## **6.0 POWER-ON-TIMER**

- 6.1 The power-on-timer is used when the loop is not powered and the unit is operating from battery power. When received, the power-on-timer is set to 60 minutes. The gauge will turn on with any key press and will remain on for 60 minutes without a key press. The power-on-timer can be set anywhere between 1 and 720 minutes (12 hours). If “0” is entered, the gauge will remain on continuously. To change the timer, press the SETUP key until the display reads “POt”, the current timer value will be displayed. Press the • or – arrow key to increase or decrease the on time; press ENTER to save. NOTE: Both setpoints must be set to “OFF” for the power-on-timer to be active.

## **7.0 BATTERY - LOW INDICATION AND REPLACEMENT**

- 7.1 The gauge is designed to give four (4) years of service life with the supplied, high energy density, extra long life lithium battery. When the battery needs replacement, the display will alternate between the pressure reading and “L.BAt”. At this time the gauge will continue to work properly. When the “L.BAt” indication displays continuously, the battery is exhausted and must be replaced. Use 1 each “C” size 3.6 volt high energy lithium battery, Tadiran models TL-5920 or TL-2200 or Saft model LS26500 or equivalent. See figure 8 for battery replacement instructions.

NOTE: DO NOT use a 1.5 volt “C” size battery.

## **8.0 CALIBRATION**

8.1 Calibration may be performed many times over the life of the gauge. Calibration can be performed from the front keypad without disassembling the gauge. To calibrate the gauge, use a dead weight tester or a test gauge as the calibration standard. The calibration standard used should have an accuracy of 0.05% of full scale or better. NOTE: During calibration, the gauge allows 2 minutes between keystrokes to change or save a new calibration. If 2 minutes lapse without a keystroke, the gauge will automatically return to the normal mode without making any changes. The new calibration information is saved only if the ENTER key is pressed and the gauge reads "SAVE/donE".

8.2 CALIBRATION PROCEDURE - To calibrate the gauge, press and hold the • key and press the SETUP key until the display reads "CAL", press ENTER; the display will read "CAL.L" for the low or zero calibration value. Adjust the standard for a reading at or near zero and press ENTER. After the "bar" timer expires, use the • or – arrow key to increase or decrease the display reading to match the reading of the standard and press ENTER; the display will read "CAL.H" for the high or span calibration value. Adjust the standard for a reading at or near full scale and press ENTER. After the bar timer expires, use the • or – arrow key to increase or decrease the display reading to match the standard and press ENTER. The display will read "SAVE/donE" and return to the normal reading with the new calibration values stored in permanent memory.

NOTE: Be sure that the units of the calibrator match the units of the gauge before performing a calibration.

8.3 The DPS-1591DP gauge has a feature that allows a slight adjustment of either the zero or span values individually. This type of calibration can be used to "tweak" the readout to match that of a known value without actually performing a formal calibration procedure. NOTE: This type of adjustment will invalidate calibration settings resulting from the procedures in the above section.

ZERO ADJUSTMENT ONLY - To make a small adjustment on the zero calibration value of the gauge, enter the calibration mode, the display reads "CAL", press ENTER; the display will read "CAL.L" for the low or zero calibration value. Adjust the standard for a reading at or near zero and press ENTER. After the "bar" timer expires, use the • or – arrow key to increase or decrease the display reading to match the reading of the standard and press ENTER. The display will read "CAL.H"; press the SETUP key and the display will read "SAVE/donE" and will return to the normal reading with the new zero calibration value stored in permanent memory.

SPAN ADJUSTMENT ONLY - To make a small adjustment on the span point of the gauge, enter the calibration mode, the display reads "CAL", press ENTER; the display will read "CAL.L". Press the SETUP key and the display will read "CAL.H" for the high or span calibration value. With the standard at or near the desired span value press ENTER and after the "bar" timer expires use the • or – arrow key to increase or decrease the display reading to match the standard and press ENTER. The display will read "SAVE/donE" and will return to the normal reading with the new span calibration value stored in permanent memory.



- 8.4 LOOP CALIBRATION PROCEDURE - The DPS-1591 current loop is factory calibrated and will not typically require field calibration. If it is necessary to re-calibrate the 4-20 mA output, the following procedure can be used. To calibrate the current loop, press and hold the • key and press the SETUP key until the display reads "CAL". Press the SETUP key until the display reads "C.LP", press ENTER; the display will read "LP.4" for the low or 4 mA calibration value. Wait one second. The unit is now displaying the 4 mA reference number for the digital to analog converter. Use the • or – arrow key to increase or decrease the displayed reference number until the measured loop current is exactly equal to 4.00 mA and press ENTER to accept the new value. The display now reads "LP.20", wait one second and the display will read the 20 mA reference value for the digital to analog converter. Use the • or – arrow key to increase or decrease the displayed reference number until the measured loop current is exactly 20.00 mA and press ENTER. The display will read "SAVE/donE" and return to the normal reading with the new calibration values stored in permanent memory.
- 8.5 SELECTING THE DEFAULT CALIBRATION - The user can at any time during the life of the gauge return to the factory calibration values. press and hold the • arrow key and press the SETUP key until the display reads "CAL", now press the SETUP key until the gauge reads "dFLt". Press ENTER and the factory calibration values will be recalled and used for the calibration of the gauge.

## 9.0 PRESSURE RANGE CHART

Available Pressure Ranges & Display Resolution									
Max Range	Max Over Pressure	Display Resolution Available Units							
psig	psig	psig	In H <sub>2</sub> O	In Hg	mm H <sub>2</sub> O	mm Hg	bar	mbar	Kg/cm <sup>2</sup>
50	100	0.1	1	0.1	1	1	0.001	1	0.001
100	200	0.1	1	0.1	1	1	0.01	1	0.01
200	400	0.1	1	1	1	1	0.01	1	0.01
500	1,000	1	1	1	-	1	0.01	1	0.01
1,000	2,000	1	1	1	-	1	0.1	1	0.1
2,500	5,000	1	-	1	-	-	0.1	-	0.1
5,000	10,000	1	-	1	-	-	0.1	-	0.1
10,000	20,000	1	-	1	-	-	1	-	1

Notes:

1. Absolute Max readout range is -14.7 psig to 110% of stated Max Range.
2. All ranges will read Vacuum down to -14.7 psig.
3. Burst pressure is 5X or 25,000 psi, whichever is less.

# DIMENSIONAL DRAWING

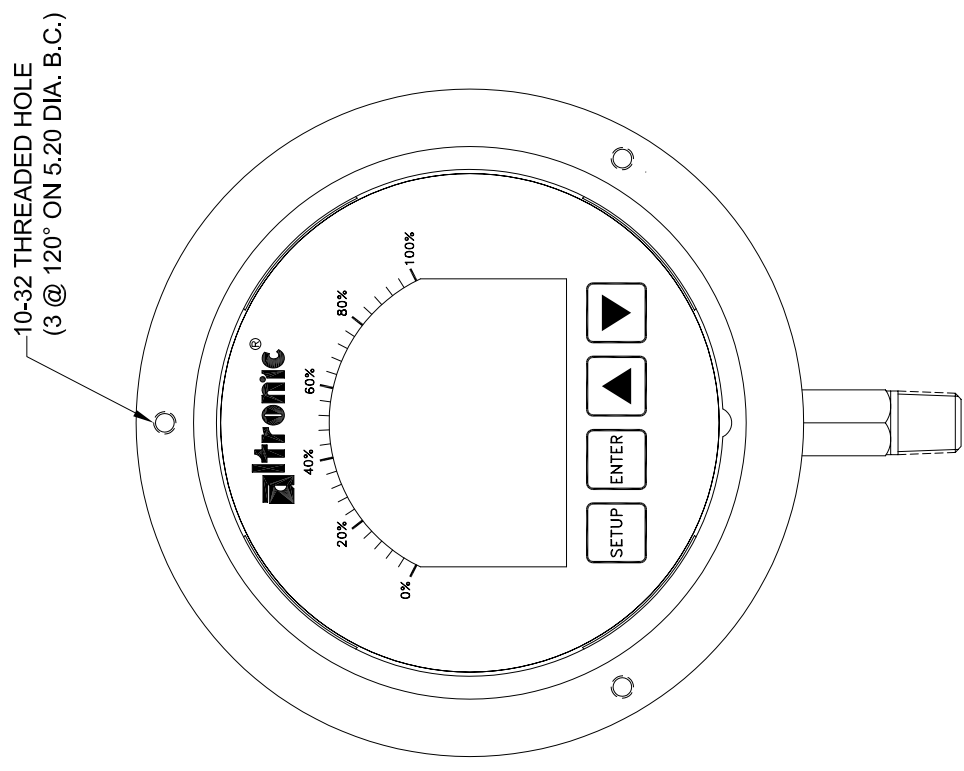
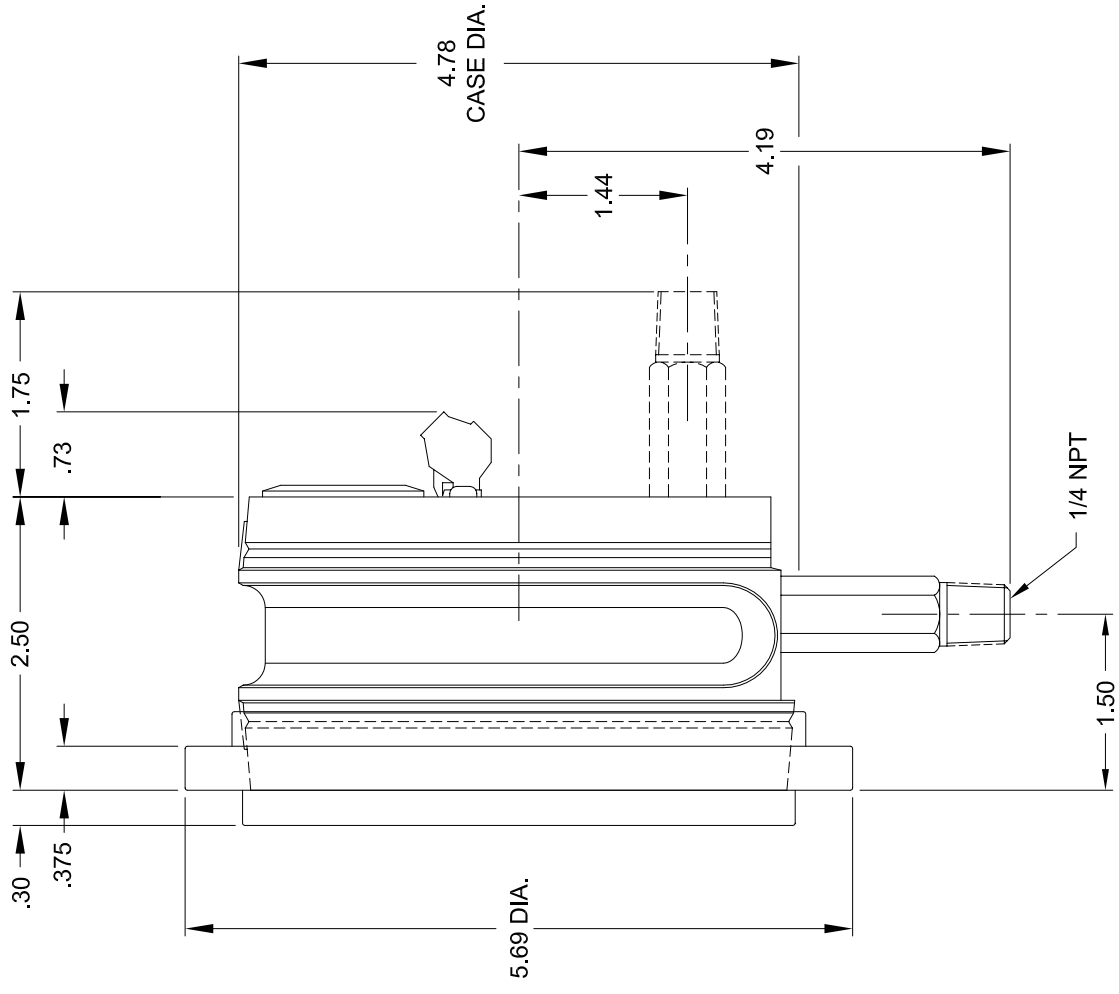

ALL DIMENSIONS ARE IN INCHES

Figure 1

# FLOWCHART - DPS-1591DP LOOP POWERED DIGITAL GAUGE

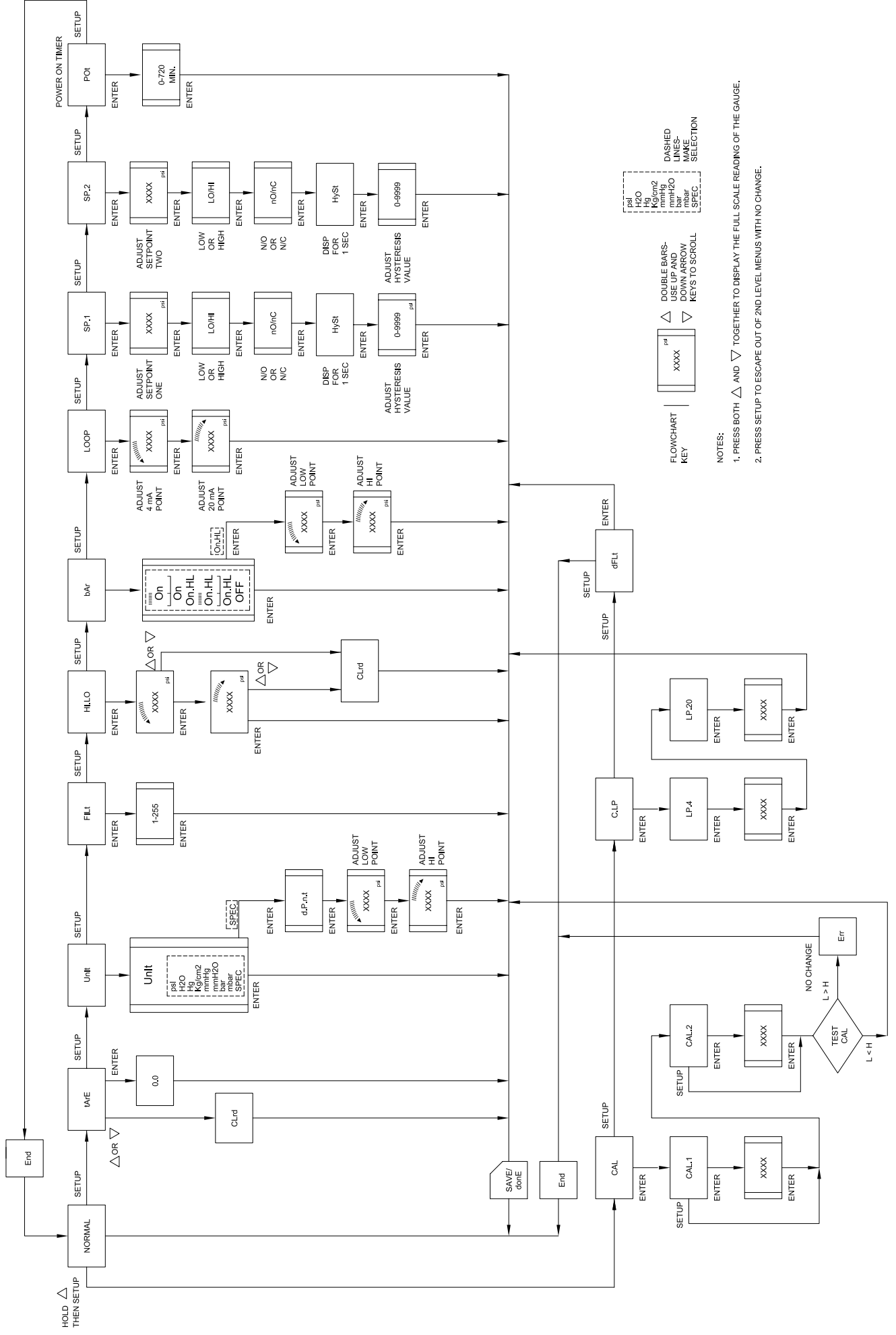
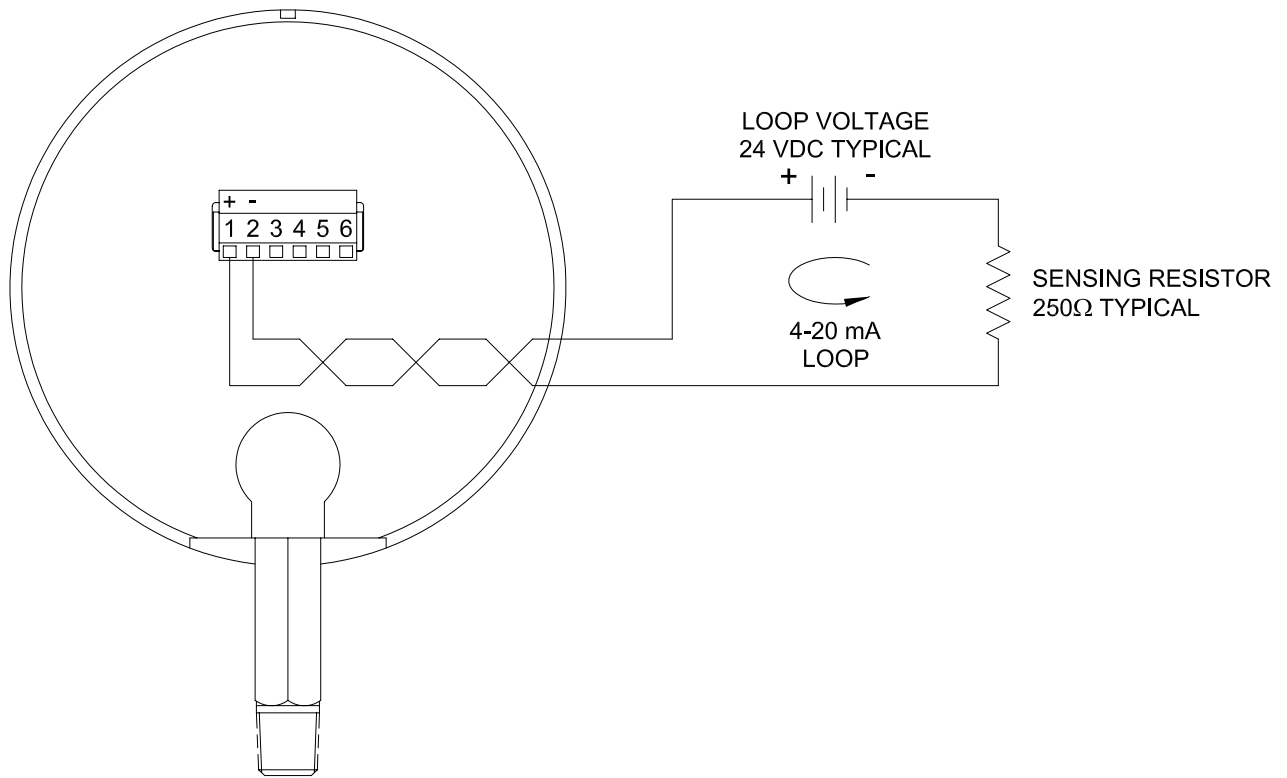

Figure 2

# WIRING DIAGRAM - CURRENT LOOP



**Figure 3**

## MAXIMUM LOAD RESISTANCE VERSUS SUPPLY VOLTAGE

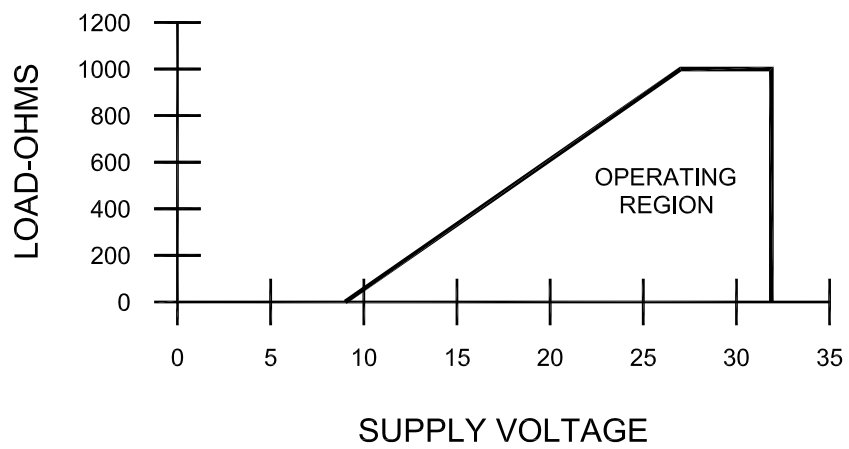

**Figure 4**

# WIRING DIAGRAM - CURRENT LOOP - INTRINSICALLY SAFE

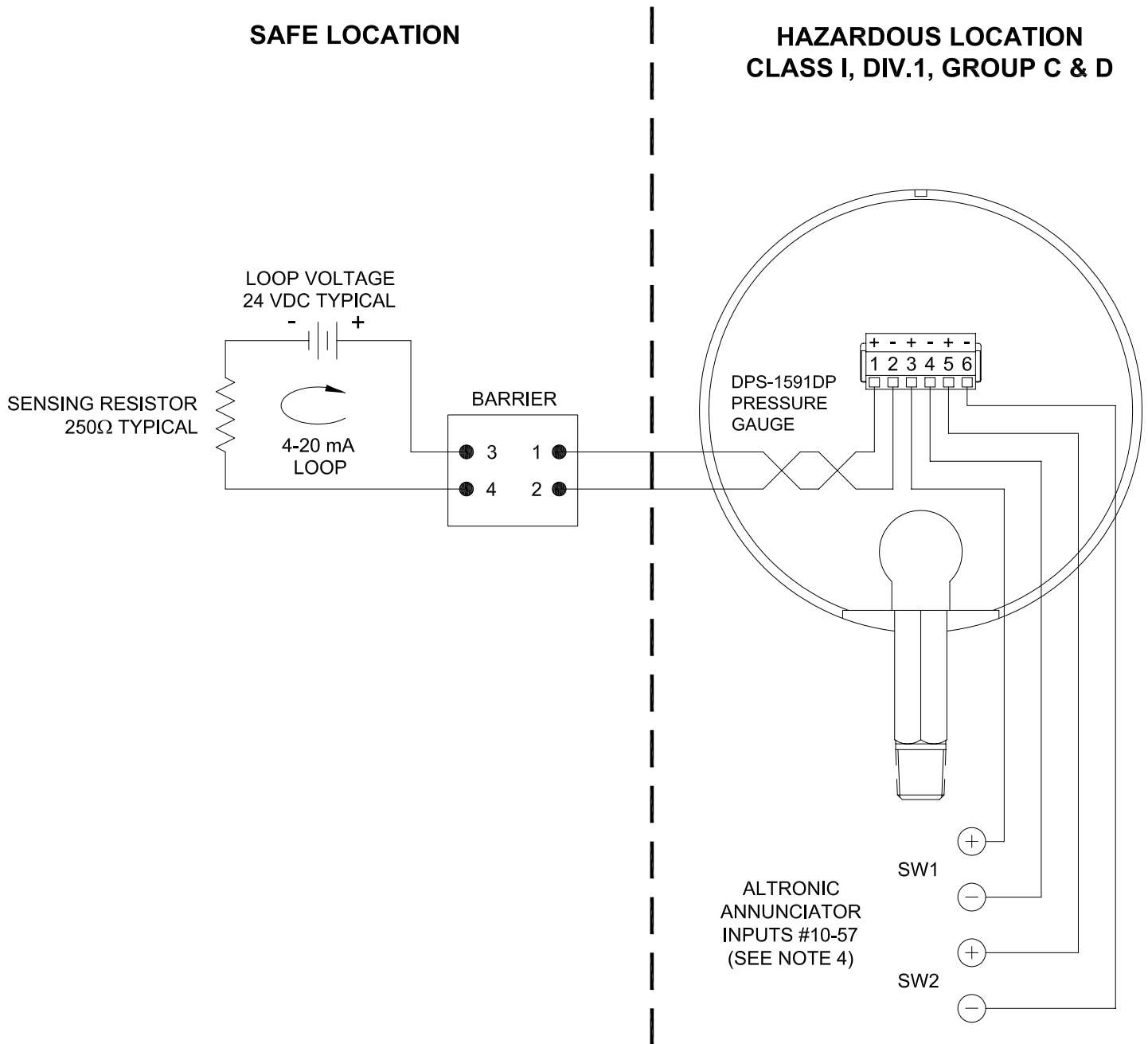

## NOTES:

1. DC POWER MUST BE FROM A CSA CERTIFIED ZENER BARRIER RATED 30 VOLTS MAX. 120Ω MIN. A SUITABLE BARRIER IS A STAHL PART NO. 9002/13-280-110-00. FOLLOW THE INSTALLATION INSTRUCTIONS SUPPLIED WITH THE BARRIER.
2. WITH STAHL 9002/13-280-110-00 THE SENSING RESISTOR CAN BE EITHER ON THE POSITIVE OR NEGATIVE SIDE OF THE SUPPLY.
3. LOOP VOLTAGE MUST BE 24 VDC NOMINAL FOR USE WITH BARRIER.
4. THE SWITCH OUTPUTS, IF USED MUST BE CONNECTED TO THE SENSOR INPUTS OF AN ALTRONIC DA OR DD ANNUNCIATOR SYSTEM WITH 690 SERIES POWER SUPPLY.
5. MAXIMUM NON-HAZARDOUS AREA VOLTAGE MUST NOT EXCEED 250V.
6. INSTALL IN ACCORDANCE WITH C.E.C. PART I.

**Figure 5**

# WIRING DIAGRAM - OUTPUT SWITCHES

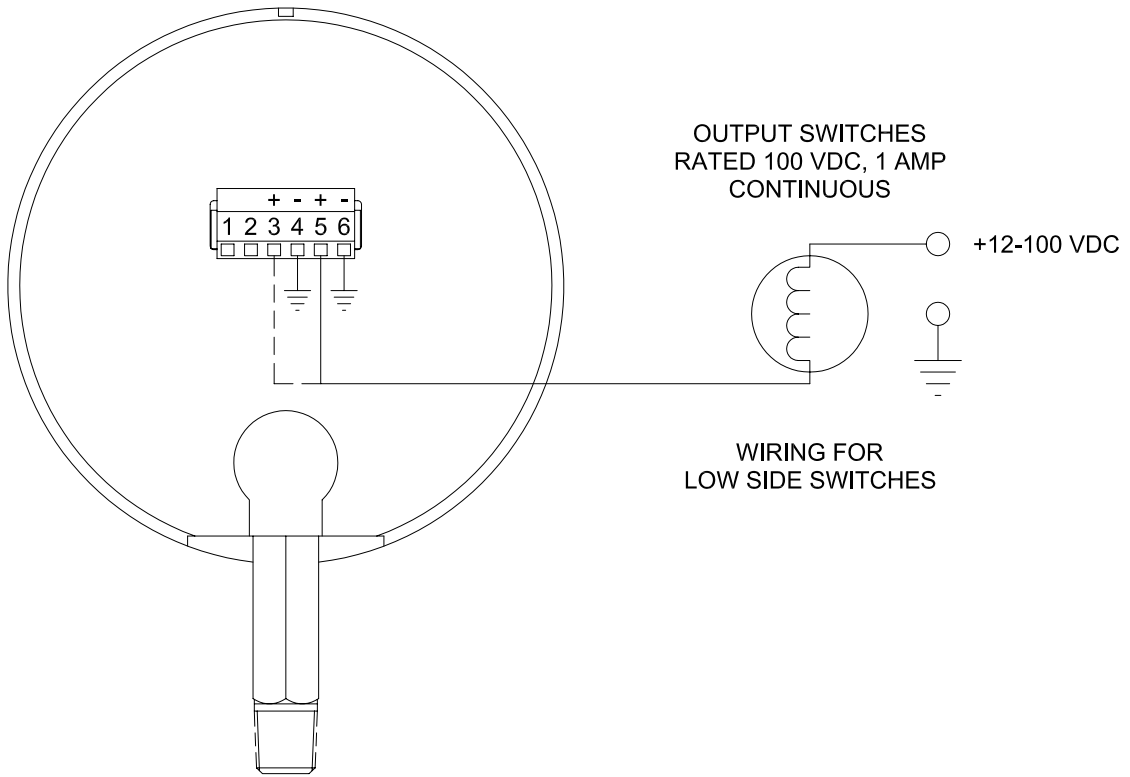

Figure 6

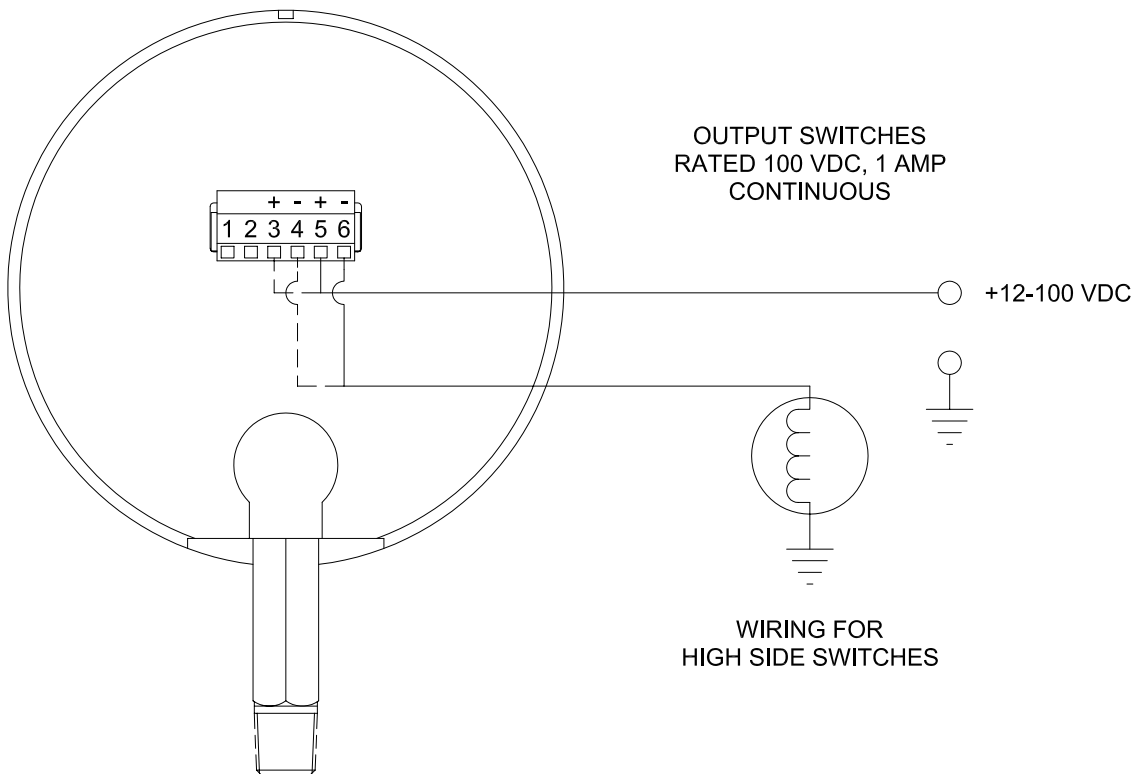
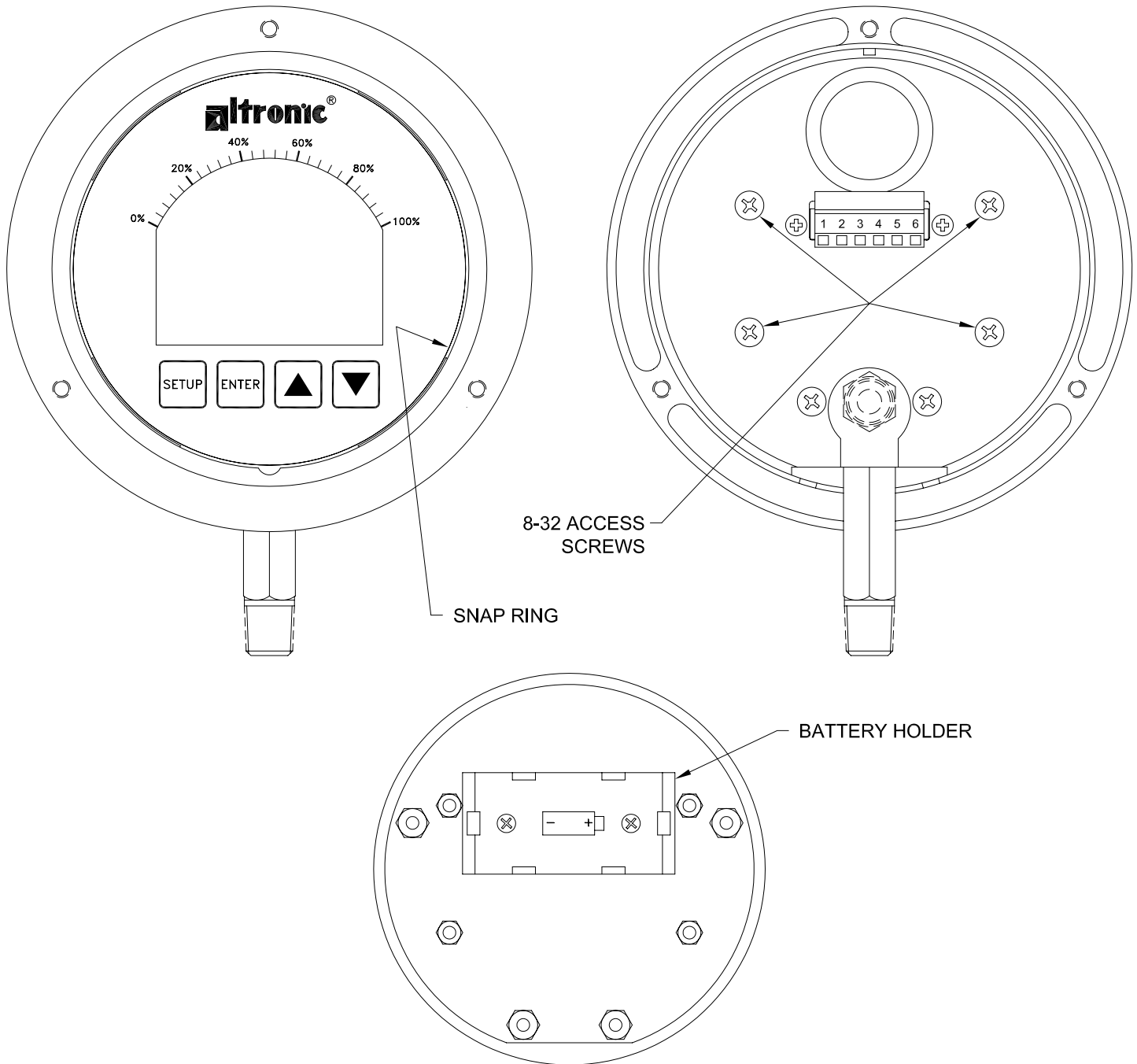

Figure 7

# BATTERY REPLACEMENT



Use 1 each "C" size 3.6 volt high energy lithium battery, Tadiran models TL-5920 or TL-2200 or Saft model LS26500 or equivalent.

**NOTE: DO NOT** use a 1.5 volt "C" size battery.

1. Remove the snap ring on the front of the gauge.
2. Remove the four access screws on the back of the gauge as shown.
3. Carefully separate the front of the gauge from the back housing.
4. Install battery as indicated on battery holder.

**Figure 8**