

CAUTION: The 45PHL series pressure switch-gauges are suitable for use in Class I, Division 1 and 2, Groups C and D hazardous locations when installed in accordance with these instructions.

WARNING: DEVIATION FROM THESE INSTALLATION INSTRUCTIONS MAY LEAD TO IMPROPER DEVICE OPERATION WHICH COULD CAUSE PERSONAL INJURY TO OPERATORS OR OTHER NEARBY PERSONNEL.

1.0 DESCRIPTION

- 1.1 The Altronic 45PHL series pressure switch-gauge is a mechanical pressure gauge in a 4-1/2" (114mm) case with high/low switch contacts. Utilizing a "direct drive" movement, the conventional C-bourdon tube used in most other pressure gauges is eliminated as are the gears, links, levers and springs used to connect the C-tube to the indicating pointer. In contrast, the 45PHL series uses a special helically-wound coil of Inconel metal, directly connected to the indicating pointer. Fewer parts means fewer problems. Regular recalibration is eliminated because there are no complex, wear-prone parts. Linearity is built-in; no span adjustment is needed. The zero adjustment is accessible from the front of the gauge. The "direct drive" design provides for longer life than even liquid-filled conventional gauges in severe service applications. Accuracy is +/-1% of span across the scale.
- 1.2 The pressure connection fitting is user adaptable on most models for either a bottom or a back connection - see paragraph 2.2 and figure 2 for details. The fittings are 1/4" NPT male up to 1000 psi and 1/2" male for 1500 psi and above. The gauge has a removable flange which can be used to front mount or back mount the gauge. The gauge can also be direct mounted.
- 1.3 The two adjustable high/low limit contacts can be used to activate alarms or shutdowns. The high/low adjustment knobs are color-coded (Red for Low, Black for High) and match the switch connection wires.
- 1.4 The basic design is inherently safe due to the very small tube I.D. The small diameter of the spiral tube effectively limits the flow rate of pressure media into the case. Polycarbonate plastic is used for the front lens and a rubber blow out plug is used in the rear wall of the case.
- 1.5 Corrosion resistant materials are used throughout making them applicable for most process applications. The case is ABS plastic, with a polycarbonate lens. The helical tube is Inconel, the pressure connection stem is 316 stainless steel, and all hardware is stainless steel.
- 1.6 The features of the 45PHL series pressure switch-gauges make them ideal for gas compressor and other high pulsation/high vibration use, offering longer life in tough applications. The 4-1/2" round, weather-resistant case fits an industry standard panel cutout allowing easy replacement of OPLFC gauges.

2.0 MOUNTING

- 2.1 Mount the switch-gauge vertically inside a control panel or to a suitable flat surface so that the dial is at a convenient viewing height. A drilling template is provided. Mount the gauge with the hardware enclosed. Make sure that the case is not distorted. Distortion of the plastic case may cause the internal assemblies to bind.

NOTE: Factory calibration is performed with the gauge dial mounted in a vertical position. If the gauge is to be used in some other position, the factory calibration should be verified in this position.

CAUTION: A rubber blowout plug is located in the back of the case. Do not mount the gauge with the blowout plug flush against a surface. Use shock mounts on inner panel to protect the gauge from high vibration.

- 2.2 On most models, the pressure connection fitting can be located for either bottom or back attachment and can be changed in the field.

NOTE: See figure 2 to change the position of the pressure connection fitting.

NOTE: Do NOT attempt to change the connection fitting position on gauge models 45PHL-30, 45PHL-30V30, and 45PHL-60.

- 2.3 To avoid contaminating the pressure measuring system in the gauge, leave the protective cap on the connection fitting until just before the connection is made. The fittings on the gauge and on the pressure line must match. A 1/4" NPT fitting is used on 45PHL gauges with pressure ranges up to 1000 psi and a 1/2" NPT fitting is used on 1500 psi and above. A thread sealant such as Teflon tape is suggested when making the connection. Take care not to clog pressure opening. Make sure the sealant used is compatible with the pressure media. Use proper wrenches to tighten or loosen connection. DO NOT use the gauge case as a handle for screwing the gauge into place on the pressure fitting. DO NOT over tighten the fittings since they may be damaged beyond repair. DO NOT exceed rated gauge pressure.

- 2.4 All Altronic 45PHL series gauges incorporate a unique needle dampening system that slows down needle bounce. However if large scale and/or high-frequency pressure fluctuations are expected in the pressure system, it may be desirable to attenuate these by use of a pulsation dampening valve. The following Altronic pulsation dampening valves are available for use with the 45PHL switch-gauges.

Stainless steel, 1/4" NPT fitting 618100-2
Steel, 1/4" NPT fitting 618100-1

- 2.5 As standard, all Altronic 45PHL series gauges are equipped with a particulate filter installed in the fitting connection of the gauge to prevent most particulate matter from plugging the spiral tube.

3.0 WIRING

- 3.1 A pressure condition at or under the low setpoint causes a switch closure on the red wire (low) and white wire (common). A pressure condition at or above the high setpoint causes a switch closure on the black wire (high) and white wire (common). Note the white wire is common with the pressure fitting (ground).

Each switch is normally open rated at 0.25 amp @ 125 volts (AC or DC). The switch contacts are gold plated at points of contact. Use stranded copper wire, 18 to 22 AWG for switch connections. Use spade or ring terminals when connecting to terminal blocks. Use wire nuts or butt connectors for pigtail connections. Conduit is recommended to protect wires from being damaged.

Caution: Connect the switches to Altronic or other electronic annunciator systems or to C.D. ignition systems with 307-PH-CD tattletales. DO NOT use 45PHL switch-gauges with type 101-PH or 307-PH tattletales.

4.0 HAZARDOUS AREA OPERATION

- 4.1 The 45PHL contains two dry contacts and can be operated with suitable precautions in Class I, Groups C & D locations.
- A. CLASS I, DIVISION 2, GROUPS C & D - Mount the 45PHL in a suitable enclosure and connect the switches to Altronic annunciator models DA, DD-NT, DD-NTS, or DE series systems.
 - B. CLASS I, DIVISION 1, GROUPS C & D (Intrinsically Safe) - Mount the 45PHL in a suitable enclosure and connect the switches to Altronic annunciator models DA or DD-NT with a division I, 690 series power supply.

5.0 OPERATION

- 5.1 When pressure is applied to the 45PHL gauge, the needle will travel clockwise for increasing pressure and counter-clockwise for decreasing pressure. The limit switches will be activated when the pointer comes in contact with the low or high setpoint contact arm. The force of the pointer causes the contact arm to flex or "tilt" causing a wiping action. This wiping action cleans the contacts and assures high reliability. In addition, all contact points are gold plated.
- 5.2 For proper operation the setpoints should be tested. Test the low setpoint by rotating the low (red) setpoint knob clockwise to meet the pointer. A low switch contact will be made. Return the low setpoint arm to the desired point below the pointer. Test the high setpoint by rotating the high (black) setpoint knob counter-clockwise to meet the pointer. A high switch contact will be made. Return the high setpoint arm to the desired point above the pointer.

- 5.3 Adjust the setpoints to the appropriate setting for the equipment protection. The recommended low setpoint range is from zero to mid-scale. The recommended high setpoint range is from mid-scale to 90% of full scale. NOTE: With the low setpoint switch connected to an Altronic annunciator on either a class B or class C point, there will be no need to manually override the low contact as this will be handled by the annunciator. If the low switch is connected to a tattletale system with no start-up timer, the low switch will have to be manually moved away from the pointer during a start condition. After the process pressure normalizes, the setpoint arm can be moved to the desired low setpoint position.

6.0 MAINTENANCE

- 6.1 The Altronic 45PHL setpoint gauge is designed to be part of a system to protect critical machinery and processes. As part of a preventative maintenance plan, these gauges should periodically be inspected and tested for proper operation. Visually check that the indicated pressure is in keeping with expected readings and that the needle is not frozen, distorted or otherwise inaccurate. Pressure fittings and tubing should be inspected to insure against leaks and blockages that could impair proper operation of the gauge. Periodically adjust the high and low knobs to cause action of the limit switches and proper alarm or shutdown action per the design of the overall safety shutdown system.

- 6.2 If the gauge seems to be working improperly, consider the possibilities that may be causing the difficulty. If the zero is off only slightly it may have been caused by over-pressures that were slightly more than 150% of the full scale range of the gauge. In this case, the zero may be reset by using a small screwdriver to turn the drive at the bottom of the dial face on the outside of the case which, in turn, rotates the gauge dial.

If over pressure has been applied in excess of 150% of the full scale range, it will be necessary to check the calibration of the gauge after resetting the zero. The gauge accuracy is guaranteed only when over pressures are less than 150% of the full scale range of the gauge. When checking the gauge calibration, it is necessary to use a reference pressure device with an accuracy of 0.25% or better. The calibration should be checked at 20% increments. These points should be checked while increasing the pressure from zero to the full scale reading and then again while decreasing the pressure from the full-scale reading to zero. Be sure that true zero pressure occurs in the pressure system at zero reading.

- 6.3 A leak may be indicated by continuously decreasing gauge readings, particularly if the pressure has been "trapped" by a valve. If this is the case, check all components in the pressure system, including the fittings and the valve, for leakage.
- 6.4 The gauge may be blocked and require cleaning. Contamination from the pressure media may be present. It may be necessary to remove and clean or replace the particulate filter. Certain accessory devices, such as isolators and pressure snubbers should be considered in certain applications.
- 6.5 It should not be necessary to open an Altronic 45PHL series gauge for adjustment, repair or other purposes. If the gauge seems to be working improperly, please follow the instructions above. If the gauge is still not working properly, return the gauge for factory service.

DIMENSIONS and SPECIFICATIONS

SPECIFICATIONS

ACCURACY

± 1% of Full Scale,
Compound Gauge 2% 20in. to 31in. Hg.

MAX. PRESSURE CAPABILITY

150% of Full Scale.
Burst Pressure: 500% of the Full Scale Pressure.

AMBIENT TEMPERATURE RANGE

-65°F to 190°F (-54°C to 88°C).

SERVICE MEDIA TEMPERATURE

-65°F to 400°F (-54°C to 204°C).

SETPOINT SWITCH RATING

125 VOLTS @ 0.25 AMPS

MATERIALS

Case - ABS Plastic, Black
Lens - Polycarbonate
Sensing Element - Inconel X-750
Capillary Tube - 316 Stainless Steel
Socket - 316 Stainless Steel
Contacts - Gold Flash

CONNECTION THREAD

0 to 1000 PSI --- 1/4" NPT
1500 to 5000 PSI --- 1/2" NPT

GAUGE
ELECTRICAL
CIRCUIT

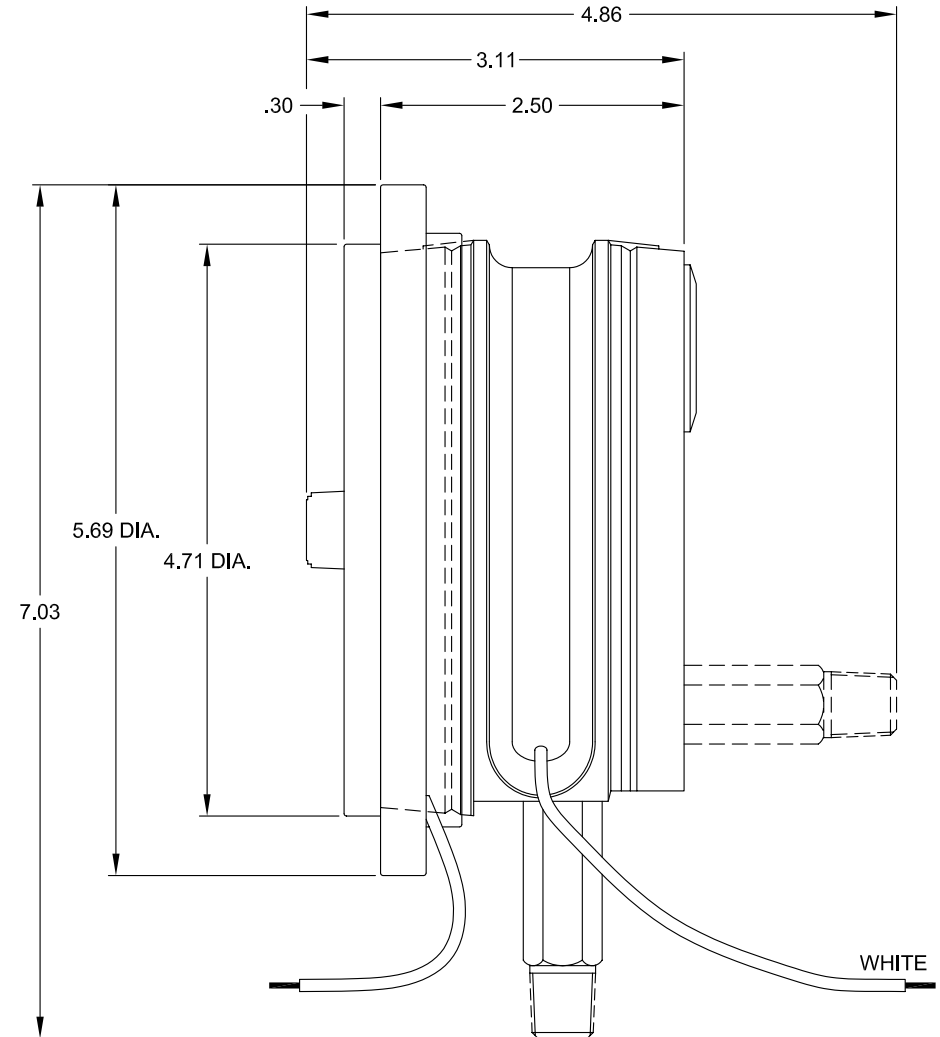
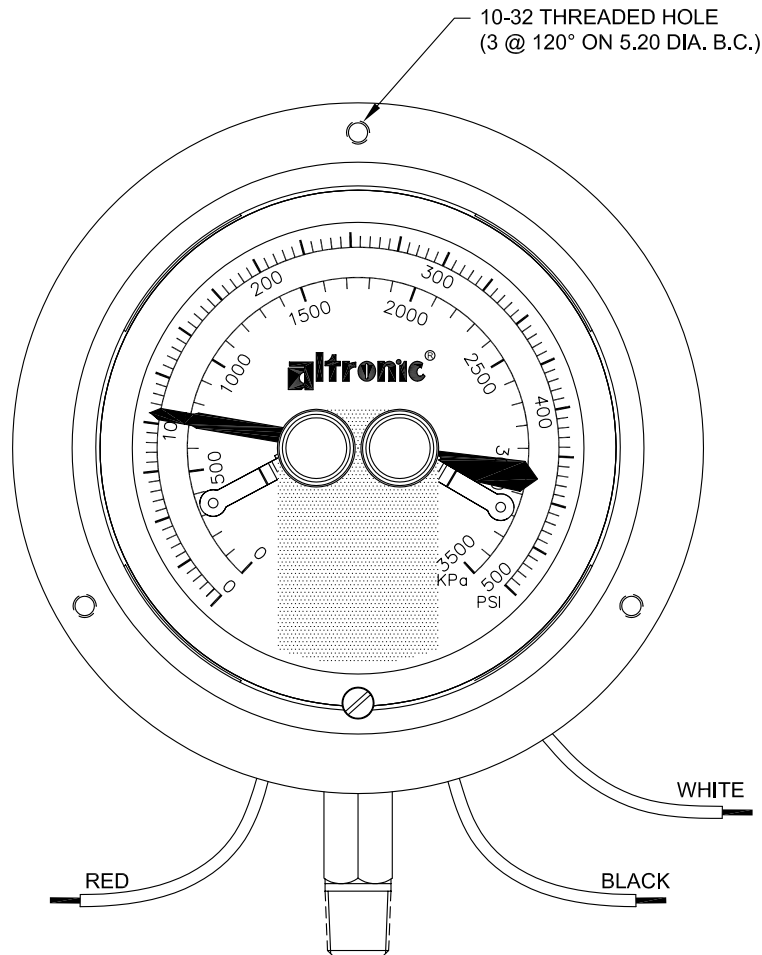
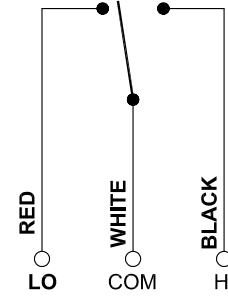
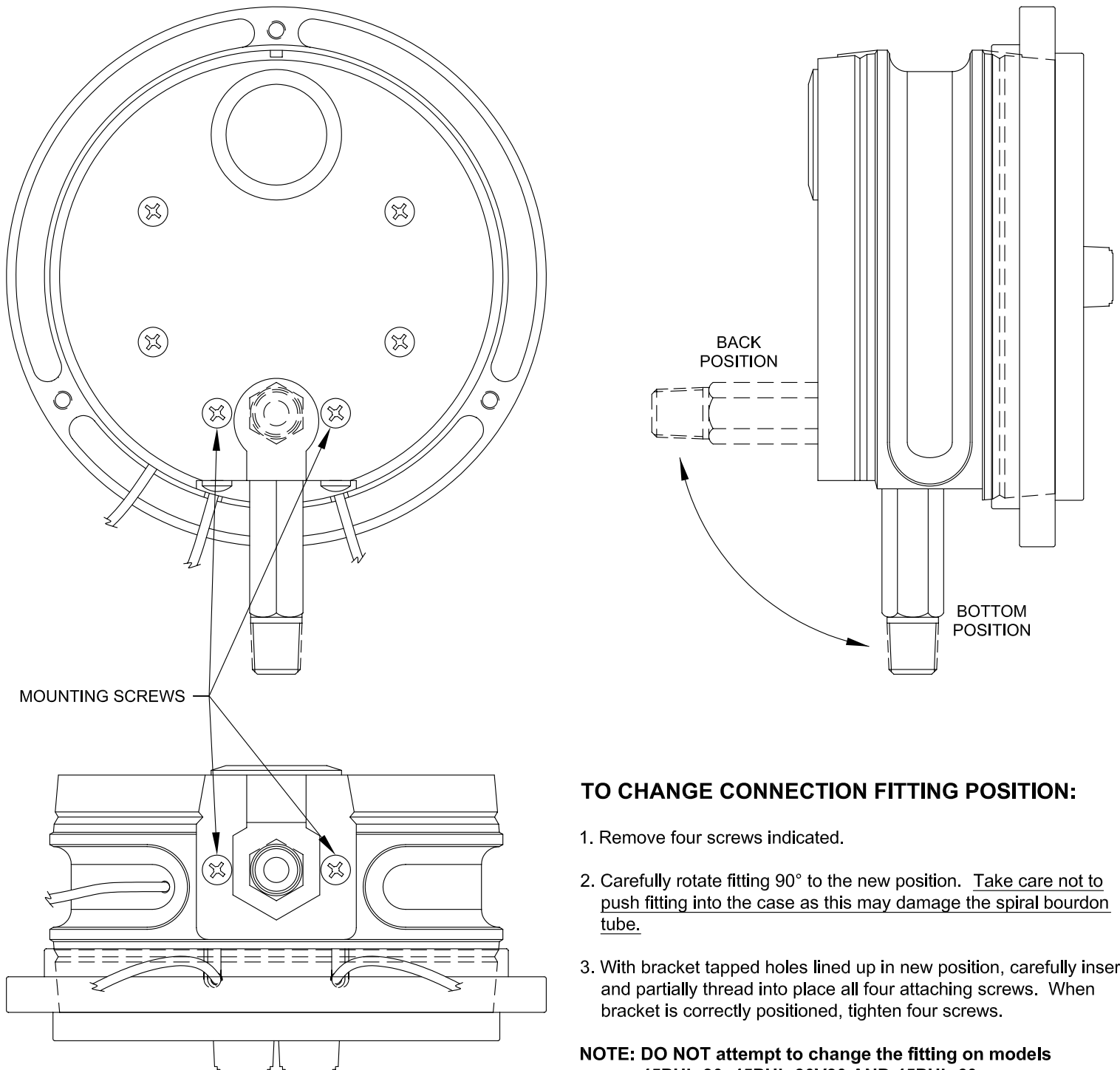

Figure 1

PRESSURE FITTING ADJUSTMENT



TO CHANGE CONNECTION FITTING POSITION:

1. Remove four screws indicated.
2. Carefully rotate fitting 90° to the new position. Take care not to push fitting into the case as this may damage the spiral bourdon tube.
3. With bracket tapped holes lined up in new position, carefully insert and partially thread into place all four attaching screws. When bracket is correctly positioned, tighten four screws.

NOTE: DO NOT attempt to change the fitting on models 45PHL-30, 45PHL-30V30 AND 45PHL-60.

Figure 2