

CAUTION: The DTHO-1201/3201 tachometers are suitable for use in Class I, Group D, Division 1 and 2 hazardous locations when installed in accordance with these instructions.

WARNING: DEVIATION FROM THESE INSTALLATION INSTRUCTIONS MAY LEAD TO IMPROPER OPERATION OF THE MONITORED MACHINE WHICH COULD CAUSE PERSONAL INJURY TO OPERATORS OR OTHER NEARBY PERSONNEL.

1.0 DESCRIPTION

- 1.1 The DTHO-1201/3201 are electronic tachometers with a 5-digit LCD display, setable overspeed output switch and an integrated run-time hourmeter. The DTHO-1201/3201 uses a quartz crystal oscillator and a microprocessor to provide a highly accurate speed indication on engines or other rotating equipment. Both the power and speed signal simultaneously come from either the shutdown lead of a C.D. industrial ignition system or from a magnetic pickup. No external power is required. An internal 3.6 volt lithium battery is used for reading accumulated hours, configuring the tachometer and setting the overspeed setting when no external power is being supplied to the tachometer. The device uses a microcontroller to process the input signal and a nonvolatile memory to store the accumulated hours, the configuration parameters and the setpoint values. An LCD display is used to display the RPM and total run-time hours as well as the various setup menus. A front mounted keypad is used to configure the tachometer. A software filter stabilizes RPM display readings where the input signal is fluctuating.
- 1.2 The monitored RPM is continuously compared against a field adjustable overspeed setpoint. The overspeed setpoint can be adjusted using the front mounted keypad within the range of the tachometer. The output switch is an isolated, normally open FET transistor.
- 1.3 The DTHO-1201/3201 incorporates a 5-digit hourmeter with 1 hour increments that records total run-time hours. The hourmeter accumulates hours when the tachometer is reading RPM. The hourmeter can be both reset and preset using the front panel keypad.
- 1.4 The device is powered from the input signal source, either a CD ignition system or a magnetic pickup.
- 1.5 For proper operation, these installation instructions must be adhered to strictly.

2.0 SIGNAL INPUT

- 2.1 The DTHO-1201/3201 series gauge is designed to accept a wide range of voltage and frequency signal inputs. The input voltage range is 100 to 400 volts (ignition) or 3 to 20 volts peak (magnetic pickup), and the frequency range is 0.2 to 10 kHz. The input signal is applied to the tachometer on either the ignition input terminals - intended for use with positive and negative ground C.D. ignition systems, or to the magnetic pickup input terminals - intended for use with magnetic pickups.
- 2.2 IGNITION INPUT - The ignition input is designed to accept frequency signals from the ignition "shutdown" lead of either a positive or negative ground C.D. ignition system with a voltage range of 100 to 400 volts peak. The connection is made to the back of the DTHO-1201/3201 at terminals 1 (+) and 2 (-). See wiring diagrams for correct hook-up.
- 2.3 MAGNETIC PICKUP INPUT - The magnetic pickup input is designed to accept frequency signals from 3 to 20 volts peak from magnetic pickups. Altronic P/N 691118-x series or equivalent magnetic pickups can be used as signal sources. Connect the 691118-x magnetic pickup to pins 3 (+) and 4 (-) on the back of the DTHO-1201/3201 tachometer as shown in the installation drawing. NOTE: Absolute minimum operating voltage required from the magnetic pickup at slow speeds is 3 volts peak.

3.0 MOUNTING

- 3.1 Mount the tachometer inside a control panel or to a suitable flat surface so that the display is at a convenient viewing height. A drilling template is provided. NOTE: Avoid mounting tachometer with the LCD display facing direct sunlight. The operating temperature range of the tachometer including the display is -40°F to +175°F (-40°C to +80°C).
- 3.2 MAGNETIC PICKUP 691118 SERIES - When used, mount the magnetic pickup securely to a rigid bracket or surface to maintain an air gap of .005"/.020" from the gear teeth to obtain the lowest operational RPM. Be sure the sensed gear will not hit the pickup for the complete 360° of rotation. For best results, a gear with 20 pitch or courser should be used.

4.0 WIRING (SEE WIRING DIAGRAMS)

- 4.1 GENERAL - Take care not to damage the insulation and take precautions against damage from vibration, abrasion or liquids in conduits. Never run low voltage magnetic pickup, or output switch wires in the same conduit as the ignition wiring or other high energy wiring such as AC line power, etc. Keep wires at least 12 inches away from all high voltage wiring. Never run the tachometer wires in the same conduit as the ignition coil wiring. Never ground the tachometer wires directly to the ignition system common coil grounds. Ground should be connected to panel ground which should be the same as engine ground.

4.2 SIGNAL INPUT WIRING:

- SHUTDOWN LEAD OF A C.D. IGNITION SYSTEM - Use terminals marked IGNITION INPUT terminals 1 and 2 when the signal and power are supplied from a C.D. ignition system. For negative ground ignition systems, connect the shutdown lead to terminal 1 (+) and ground terminal 2 (-) to panel ground. For positive ground ignition systems, connect the shutdown lead to terminal 2 (-) and ground terminal 1 (+) to panel ground. The ground connection should be made by placing a short ground wire from the terminal on the back of the tachometer to panel ground which should be the same as engine ground. Use a fine gauge stranded wire such as Altronic 603102 (black) and 603103 (white) 24 AWG for ignition power connections. DO NOT connect the ground connection from the tachometer directly to the ignition system common coil ground on the engine.
- MAGNETIC PICKUP - Connect the two wires from the 691118 series or similar magnetic pickup to the back of the tachometer at terminals 3 and 4 using cable assembly 693104 series.

- 4.3 OUTPUT SWITCH WIRING - An overspeed condition will cause the output switch, which is normally open, to close between terminals 5 (+) and 6 (-). The shelf state (unpowered) is an open condition. The output switch is a solid state FET type transistor that is isolated from the input signal power source and is nonlatching. The switch is rated at 400 V, 140 mA max. The output switch may be connected to an Altronic annunciator system or to pilot duty relays as shown in the wiring diagrams. Please note that the output switch does not stay latched when the RPM value goes below the setpoint value.

WARNING: THE OUTPUT SWITCH ON THE DTHO-1201/DTHO-3201 IS NON-LATCHING. WHEN USED FOR OVERSPEED, A LATCHING DEVICE (ALTRONIC ANNUNCIATOR SYSTEM OR TATTLETALE) MUST BE USED TO GROUND THE IGNITION SYSTEM SHUTDOWN LEAD.

- 4.4 HAZARDOUS AREA OPERATION - The DTHO-1201/3201 tachometer is CSA-certified for CLASS I, DIVISION 2, GROUPS C & D areas when mounted in a suitable enclosure. The device may be operated as CLASS I, DIVISION 1, GROUPS C & D intrinsically safe, if the following conditions are met:

- A. The tachometer is powered from the Altronic barrier P/N 690107 or 690108 (follow the installation instructions supplied with the barrier) or powered from the Altronic magnetic pickup P/N 691118 series.
- B. The switch outputs, if used, are connected to the sensor inputs of an Altronic DA or DD annunciator system with the 690 series power supply.

In addition, the following requirements must be met (see NFPA standard no. 493):

- 1. The intrinsically-safe gauge wires within the panel enclosure must be kept at least two (2) inches away from other wiring.
- 2. Wiring to valves, actuators and other control devices must have a grade of insulation capable of withstanding an AC voltage of 500 volts RMS.
- 3. Control wires must be run in separate conduits and junction boxes from high voltage wires such as Ignition, fuel valve, and other high voltage wiring.

WARNING: SUBSTITUTION OF COMPONENTS MAY IMPAIR INTRINSIC SAFETY AND/OR SUITABILITY FOR CLASS I, DIVISION 2.

DO NOT DISCONNECT EQUIPMENT IN A DIVISION 2 ENVIRONMENT UNLESS POWER IS SWITCHED OFF OR THE AREA IS KNOWN TO BE NON-HAZARDOUS.

5.0 NORMAL OPERATION

5.1 In this document, when the DTTHO-1201/3201 tachometer displays a RPM value, it is in the "normal" operation mode.

6.0 KEYPAD DESCRIPTION

6.1 The DTTHO-1201/3201 tachometer contains a four-key front keypad which is used to view or change the setpoint value and to configure the tachometer and hourmeter. The four front panel keys are MODE, ENTER, and ▲, ▼ (up and down arrow keys).

6.2 MODE - The MODE key is used to enter configuration (or program) mode and to scroll through the tachometer setup menu.

6.3 ENTER - The ENTER key is used to accept and save the new data to nonvolatile memory. At the end of a configuration when a new setup has been entered, press ENTER and the display will read "SAVE", the new data or configuration will be stored in the nonvolatile memory.

6.4 ▲ ▼ - The up and down arrow keys are used to increase or decrease setup and setpoint values. These keys when held will rapidly increase or decrease display values.

7.0 DEFAULT FACTORY SETTINGS

7.1 The DTTHO-1201/3201 series tachometer contains a default setting for the overspeed setpoint. When programming the tachometer for engine operation - selecting "EnG" and pressing ENTER - the overspeed setting will default to 200 RPM. When programming the tachometer for turbo operation - selecting "turbo" and pressing ENTER - the overspeed setting will default to 2000 RPM. The overspeed setting, if used, should be set accordingly. See section 9.0 ADJUSTING SETPOINTS below.

8.0 TACHOMETER CONFIGURATION

- 8.1 When received, the tachometer will be powered with its internal 3.6 volt lithium battery, (reading "0" RPM) this allows for easy setup of the tachometer on the bench. The tachometer must be programmed for proper operation. Program the tachometer for use on either engines or turbochargers and set the input pulses per revolution. To view the current settings, press the MODE key twice, the display will read either "EnG." (Engine) or "turbo" (turbocharger). Press the MODE key again to display the pulses per revolution "P:X", X is the numeric value representing the pulses per revolution the tachometer is currently set for. To program the tachometer, press and hold the ENTER key and press the MODE key. This allows configuration changes to be made to the tachometer. A flowchart is provided that shows step-by-step progression through the tachometer configuration procedure. NOTE: An error message will appear if the user tries to make changes to the tachometer configuration without entering the two key ENTER, MODE sequence.
- 8.2 "EnG." or "turbo" - The tachometer can be set-up to read RPM in 1 RPM increments up to 9999 RPM on the "EnG" configuration, or in 100 RPM increments up to 99900 RPM in the "turbo" configuration. Press and hold the ENTER key and press the MODE key. This allows configuration changes to be made. Press the MODE key until the display reads either "EnG." or "turbo". To access the other selection (either "EnG." or "turbo"), press the ▲ and ▼ arrow keys together. After a selection has been made, press the ENTER key, the display will read "SAVE"; it is at this time that the new data is saved. To abort the configuration mode, either wait 30 seconds with no key press or continue pressing the MODE key to return to the "normal" RPM reading. During configuration, the tachometer allows 30 seconds between keystrokes to view or change and save a new configuration. If the time lapses without a keystroke, the tachometer will automatically return to the normal RPM mode without making any changes. The new information is saved only if the ENTER key is pressed and the tachometer reads "SAVE".
- 8.3 PULSE COUNT "P:" - To set the pulse count, or number of input pulses per revolution, enter the program mode as described above. Press the MODE key until the display reads "P: X" (pulses per revolution), X is the numeric value representing the pulses per revolution; the previous numeric value representing the pulse count will be shown. Use the ▲ or ▼ arrow key to increase or decrease the value until the desired pulse count is reached. Press ENTER to accept and save the new value. The tachometer will now be set for the desired pulse per revolution count. The pulse count range is .5 to 450 pulses per revolution for engine applications and .1 to 45.0 for turbo applications. NOTE: The tachometer reads the pulse count as the number of pulses seen in one engine revolution. When the signal is from C.D. ignition systems, the entered pulse rate must allow for 2 or 4 cycle and dual-storage capacitors. See examples below.

INPUT CONFIGURATION EXAMPLES - To configure the input of the tachometer to indicate correct engine RPM, the number of pulses being sent to the tachometer during one (1) revolution must be known. The following examples will help determine this number.

IGNITION SYSTEM APPLICATION USING SHUTDOWN LEAD:

NOTE: n = no. of engine cylinders

APPLICATION	P:
2-cycle, single capacitor	n
2-cycle, dual capacitor	n/2
4-cycle, single capacitor	n/2
4-cycle, dual capacitor	n/4

PICKUP APPLICATIONS:

NOTE: RATIO = gear speed : display speed

APPLICATION	TEETH	RATIO	CALC.	P:
crankshaft gear	360	1:1	360	360
camshaft gear	180	2:1	90	90
1.56 faster than display	72	.64:1	46.15	46
0.45 slower than display	30	2.22:1	66.67	67

9.0 ADJUSTING SETPOINTS

- 9.1 The overspeed setpoint can be set anywhere within the range of the tachometer. The output switch is normally open below the trip point and closes above the setpoint. The output switch is nonlatching. To view the setpoint value, press the MODE key until the display reads "XXXX" RPM, this is the current setpoint value. To change the setpoint value, press and hold the ENTER key and press the MODE key. Press the MODE key until the display reads "XXXX" RPM, this is the current setpoint value. To change the value, press the ▲ or ▼ (the up or down arrow key) to increase or decrease the value until the desired trip point is reached; press ENTER to accept and save the new value. When in the program mode, the previous setpoint value continues to be monitored; the new value is monitored only when the ENTER key is pressed and the display says "SAVE". If no key is pressed for 30 seconds, the display will return to the normal mode. Note: When set to "EnG" the setpoint range is 0 to 9999 RPM in 1 RPM increments. When set for "Turbo", the setpoint range is 0 to 99900 RPM in 100 RPM increments.
- 9.2 The overspeed switch has a fixed hysteresis value of 10 RPM when set to "EnG" and 100 RPM when set to "turbo". So for example, if the overspeed setpoint is set to 900 RPM, the output switch will close when the tachometer reaches 900 RPM and stay tripped or closed until the RPM goes below 890 RPM; at that point the switch will return to the open state.

10.0 HOURMETER OPERATION

- 10.1 The built-in run-time hourmeter is a 5-digit hourmeter with a 99,999 hour range and a resolution of 1 hour. To display hours, press the ▲ or ▼ arrow key from the normal RPM screen, the display will read “XXXXX HOURS”. The display will show the hours for 30 seconds and then revert back to the RPM reading. NOTE: If the battery is removed, the accumulated hours will be retained; this data is saved in EEPROM every hour.
- 10.2 RESET HOURMETER - To reset or preset the hourmeter, enter the program mode as described above. The hourmeter screen will show 5 digits with leading zero's displayed. The display will show the current accumulated hours along with the “HOURS” in the lower right side of the LCD. To reset the hourmeter, use the ▼ arrow key to decrease the value to zero and press ENTER. To preset the hourmeter, use the ▲ or ▼ arrow key to increase or decrease the value until the desired value is reached. Press ENTER to accept and save the new value. The hourmeter will count up from the pre-set value when an RPM signal is calculated and displayed.

11.0 BATTERY - LOW INDICATION AND REPLACEMENT

- 11.1 The tachometer is designed to give in excess of five (5) years of service life with the supplied, high energy density, extra long life lithium battery. To test the battery, press the MODE key, the display will show “tEst”, press ENTER and the display will show “bAt.” for a good battery and “bAt.LO” when the battery needs replaced. Use 1 each “AA” size 3.6 volt high energy lithium battery, Tadiran model TL-5903/S or equivalent, Altronic P/N 601952. See figure 11 for battery replacement instructions.

NOTE: DO NOT use a 1.5 volt “AA” size battery.

<p>WARNING: TO PREVENT IGNITION OF A HAZARDOUS ATMOSPHERE, THE BATTERY MUST ONLY BE CHANGED IN AN AREA KNOWN TO BE NON-HAZARDOUS .</p>

FIGURES SECTION:

- FIG. 1A MOUNTING DIMENSIONS AND SPECIFICATIONS - DTHO-1201
- FIG. 1B MOUNTING DIMENSIONS AND SPECIFICATIONS - DTHO-3201

- FIG. 2 DTHO1201/3201 FLOWCHART

- FIG. 3 GENERAL ELECTRICAL CONNECTIONS

- FIG. 4 WIRING DIAGRAM - NEGATIVE GROUND C.D. IGNITION SHUTDOWN LEAD

- FIG. 5 WIRING DIAGRAM - POSITIVE GROUND C.D. IGNITION SHUTDOWN LEAD

- FIG. 6 WIRING DIAGRAM - MAGNETIC PICKUP INPUT

- FIG. 7A WIRING DIAGRAM - ANNUNCIATOR SYSTEMS/INTRINSICALLY SAFE/NEG. GND
- FIG. 7B WIRING DIAGRAM - ANNUNCIATOR SYSTEMS/INTRINSICALLY SAFE/POS. GND
- FIG. 7C WIRING DIAGRAM - ANNUNCIATOR SYSTEMS/INTRINSICALLY SAFE MAGNETIC PICKUP

- FIG. 8 WIRING DIAGRAM - DC RELAY

- FIG. 9 WIRING DIAGRAM - TATTLETALE

- FIG. 10 WIRING DIAGRAM - PNEUMATIC VALVE

- FIG. 11A BATTERY REPLACEMENT - DTHO-1201
- FIG. 11B BATTERY REPLACEMENT - DTHO-3201

FIG. 1A DTHO-1201 MOUNTING DIMENSIONS AND SPECIFICATIONS

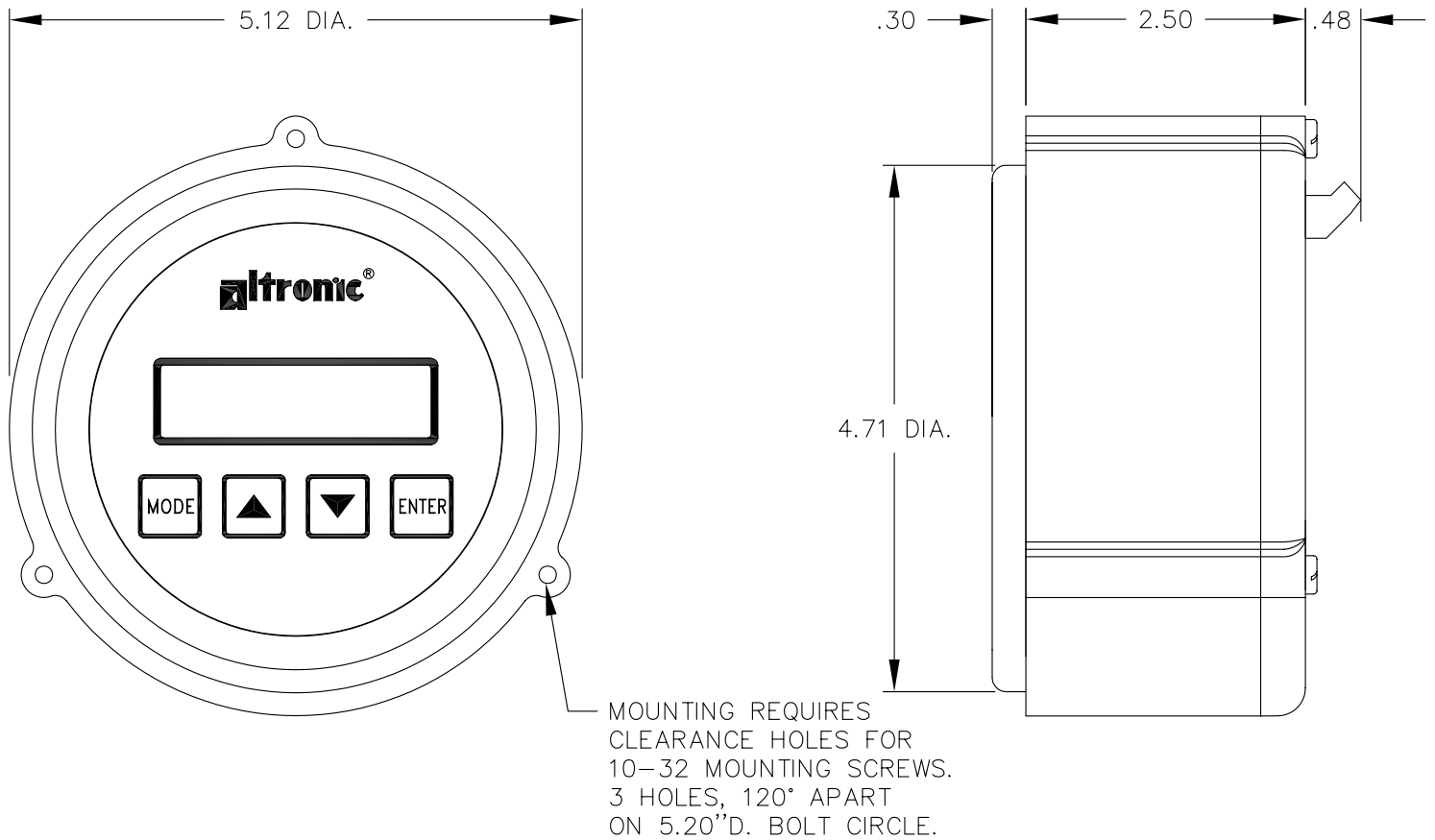

SPECIFICATIONS:

POWER AND

SIGNAL INPUT: C.D. IGNITION "SHUTDOWN LEAD" (100 - 400V),
OR VARIABLE RELUCTANCE MAGNETIC PICK-UP: (3-20V PEAK)

CONFIGURATION: PROGRAMMABLE INPUT PULSE COUNT, ABILITY TO
ACCEPT INPUTS FROM UNEVEN PATTERNS.

DISPLAY: .4" 5 DIGIT LCD WITH DISPLAY INDICATORS.

RANGE: 0 TO 9999 (ENGINE), 0 TO 99,900 (TURBO).

DISPLAY UPDATE RATE: 1 TIME PER SECOND WITH DISPLAY FILTER.

INSTRUMENT ACCURACY: $\pm 0.5\%$, ± 1 DIGIT.

AMBIENT TEMPERATURE RANGE: -40° TO 175° F (-40° TO $+80^{\circ}$ C).

SETPOINTS: 1 USER PROGRAMMABLE NORMALLY OPEN OVERSPEED SETPOINT.

OUTPUT SWITCH RATING: 400 VDC, 140mA CONTINUOUS.

HAZARDOUS AREA CLASSIFICATION: CLASS I, DIVISION 2, GROUPS C & D FOR DIRECT HOOK-UP.
INTRINSICALLY SAFE SÉCURITÉ INTRINSEQUE Exia.
CLASS I, DIVISION 1, GROUP D WHEN POWERED FROM
AN ALTRONIC ZENER BARRIER P/N 690107 OR 690108.
CLASS I, DIVISION 1, GROUPS C & D WHEN POWERED
FROM AN ALTRONIC 691118 MAGNETIC PICKUP.
MAX. AMBIENT TEMP. 80° C. T3

FIG. 1B DTHO-3201 MOUNTING DIMENSIONS AND SPECIFICATIONS

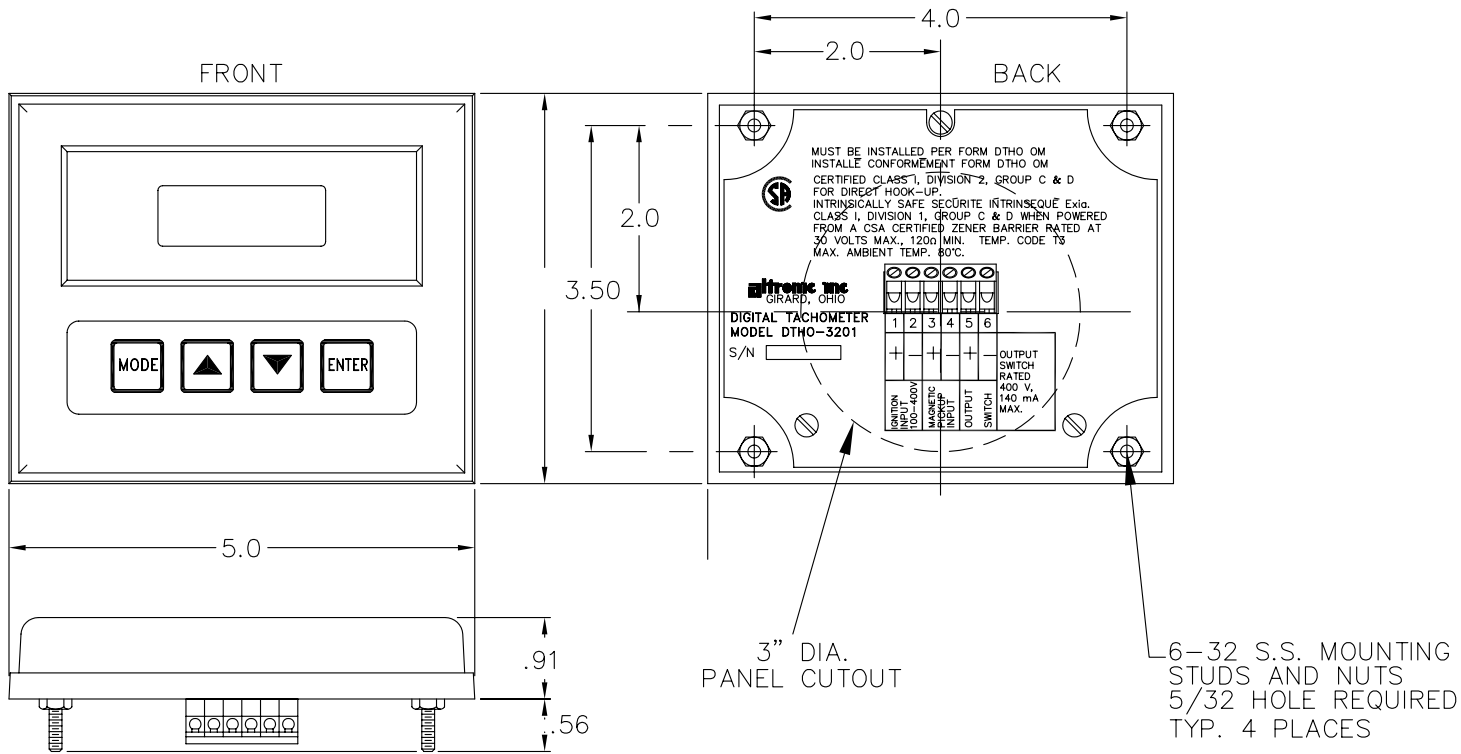

SPECIFICATIONS:

POWER AND

SIGNAL INPUT: C.D. IGNITION "SHUTDOWN LEAD" (100 – 400V),
OR VARIABLE RELUCTANCE MAGNETIC PICK-UP. (3–20V PEAK)

CONFIGURATION: PROGRAMMABLE INPUT PULSE COUNT, ABILITY TO
ACCEPT INPUTS FROM UNEVEN PATTERNS.

DISPLAY: .4" 5 DIGIT LCD WITH DISPLAY INDICATORS.

RANGE: 0 TO 9999 (ENGINE), 0 TO 99,900 (TURBO).

DISPLAY UPDATE RATE: 1 TIME PER SECOND WITH DISPLAY FILTER.

INSTRUMENT ACCURACY: $\pm 0.5\%$, ± 1 DIGIT.

AMBIENT TEMPERATURE RANGE: -40° TO 175°F (-40° TO $+80^{\circ}\text{C}$).

SETPOINTS: 1 USER PROGRAMMABLE NORMALLY OPEN OVERSPEED SETPOINT.

OUTPUT SWITCH RATING: 400 VDC, 140mA CONTINUOUS.

HAZARDOUS AREA CLASSIFICATION: CLASS I, DIVISION 2, GROUPS C & D FOR DIRECT HOOK-UP.
INTRINSICALLY SAFE SECURITE INTRINSEQUE Exia.
CLASS I, DIVISION 1, GROUP D WHEN POWERED FROM
AN ALTRONIC ZENER BARRIER P/N 690107 OR 690108.
CLASS I, DIVISION 1, GROUPS C & D WHEN POWERED
FROM AN ALTRONIC 691118 MAGNETIC PICKUP.
MAX. AMBIENT TEMP. 80°C . T3

FIG. 2 DTHO-1201 / DTHO-3201 FLOWCHART

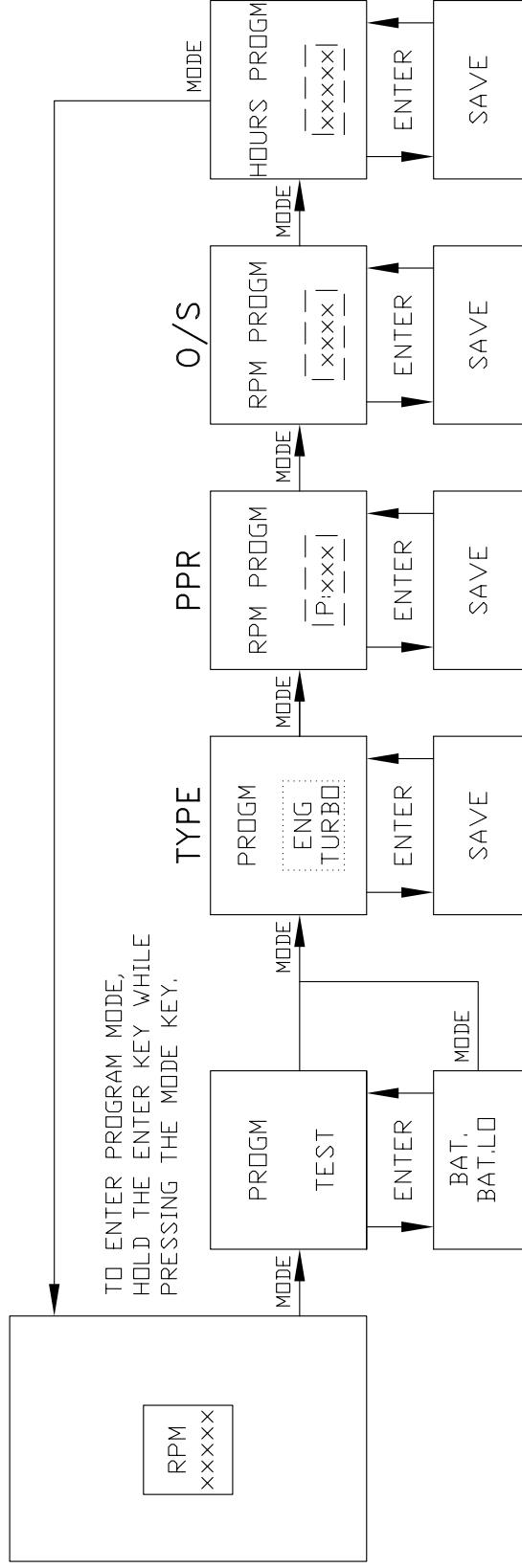

PROGRAM TEST - BATTERY TEST

TYPE SELECTION - ENGINE OR TURBO

P:RPM PROGM - PPR (PULSES PER REVOLUTION)

RPM PROGM - RPM OVERSPEED

HOURS - RESET OR PRESET HOURS

NOTE: DASHED LINES, USE ▲ OR ▼ ARROW KEYS TO CHANGE.

NOTE: ENG / TURBO, USE ▲ AND ▼ ARROW KEYS TO CHANGE.

FIG. 3 DTHO-1201/3201 GENERAL ELECTRICAL CONNECTIONS

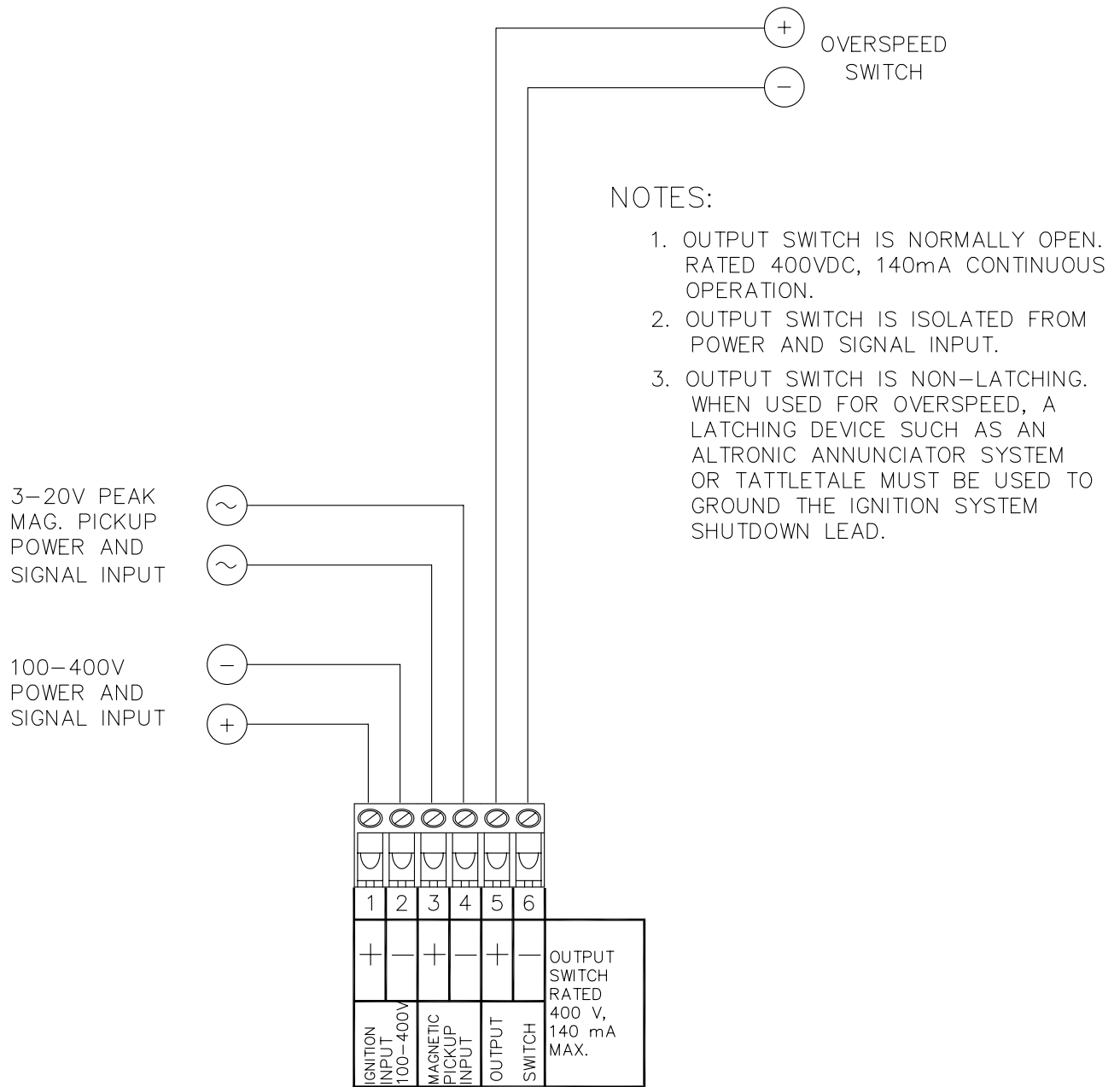

FIG. 4 DTHO-1201/3201 WIRING DIAGRAM
 NEGATIVE GROUND C.D. IGNITION SHUTDOWN LEAD INPUT

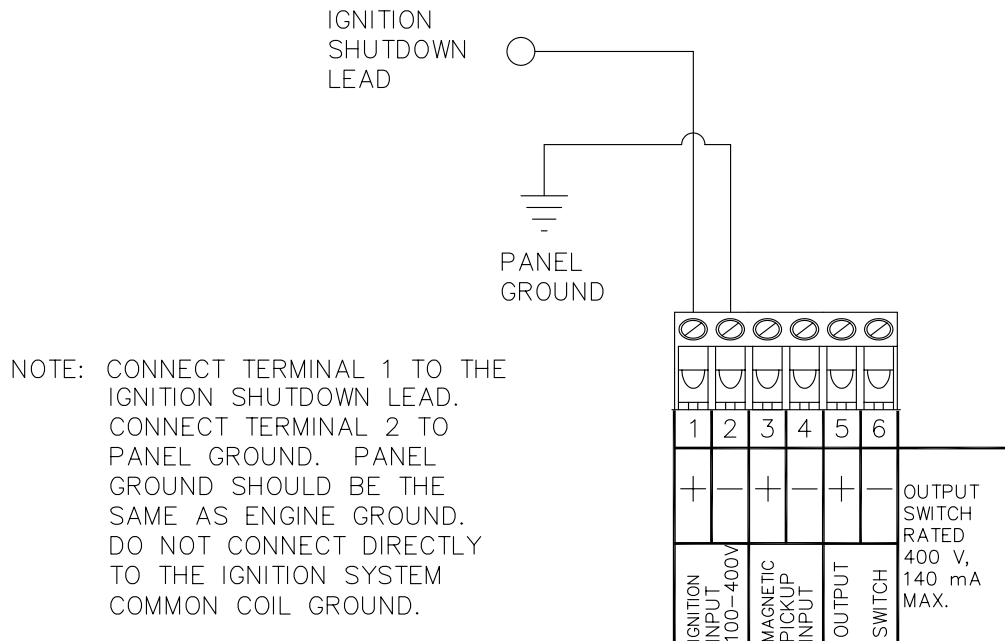

FIG. 5 DTHO-1201/3201 WIRING DIAGRAM
 POSITIVE GROUND C.D. IGNITION SHUTDOWN LEAD INPUT

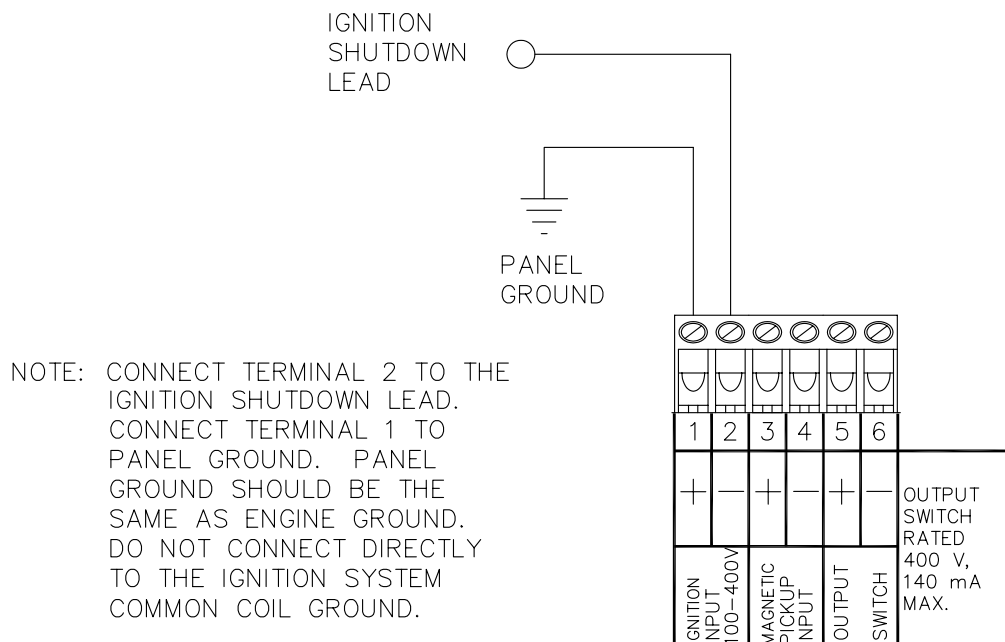

FIG. 6 DTHO-1201/3201 WIRING DIAGRAM
MAGNETIC PICKUP INPUT

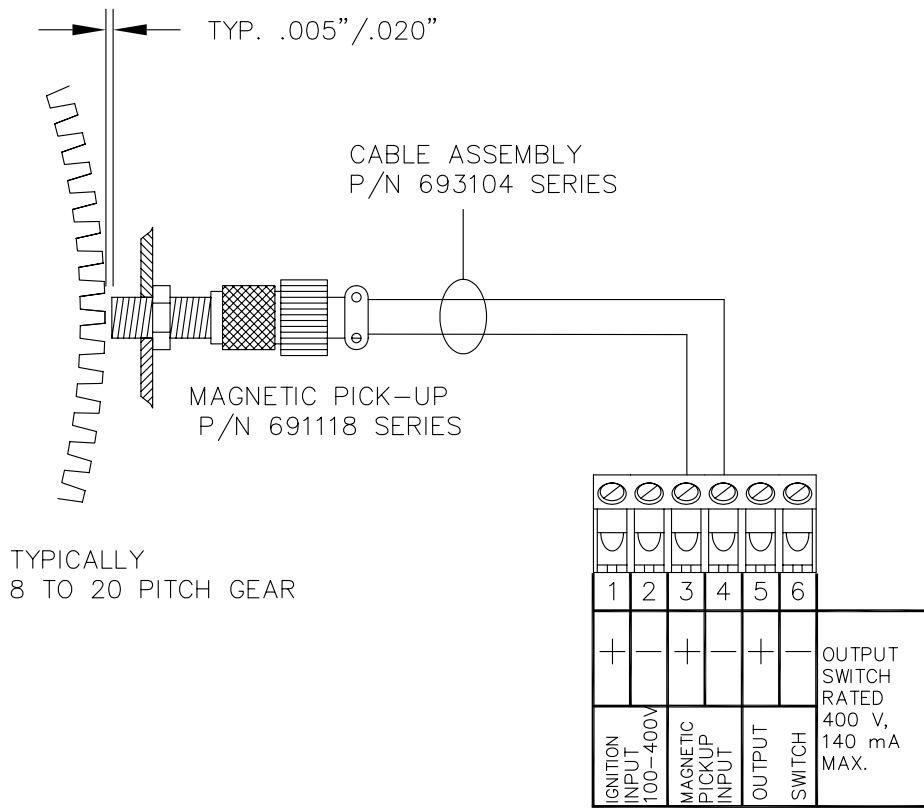
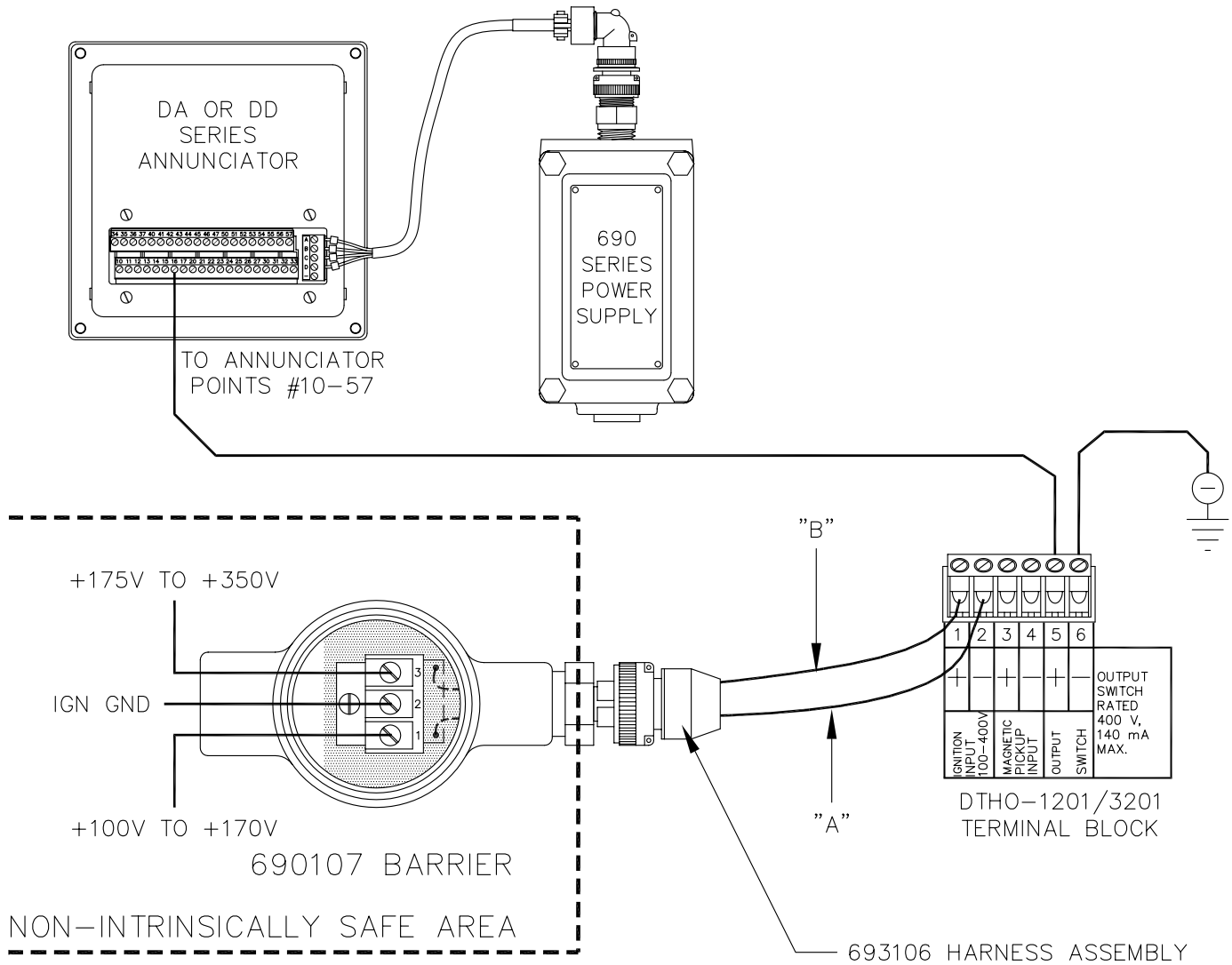

FIG. 7A DTHO-1201/3201 WIRING DIAGRAM INTRINSICALLY SAFE FOR NEGATIVE GROUND IGNITIONS



NOTES:

1. FOR CLASS I, DIV 1, GROUP D, INTRINSICALLY SAFE OPERATION, POWER THROUGH AN ALTRONIC 690107 ZENER BARRIER (FROM A CD IGNITION SHUTDOWN LEAD). FOLLOW ALL INSTRUCTIONS SUPPLIED WITH THE BARRIER. IF USED, CONNECT OUTPUT SWITCH TO DA OR DD SERIES ANNUNCIATOR WITH 690 SERIES POWER SUPPLY.

FIG. 7B DTHO-1201/3201 WIRING DIAGRAM INTRINSICALLY SAFE FOR POSITIVE GROUND IGNITIONS

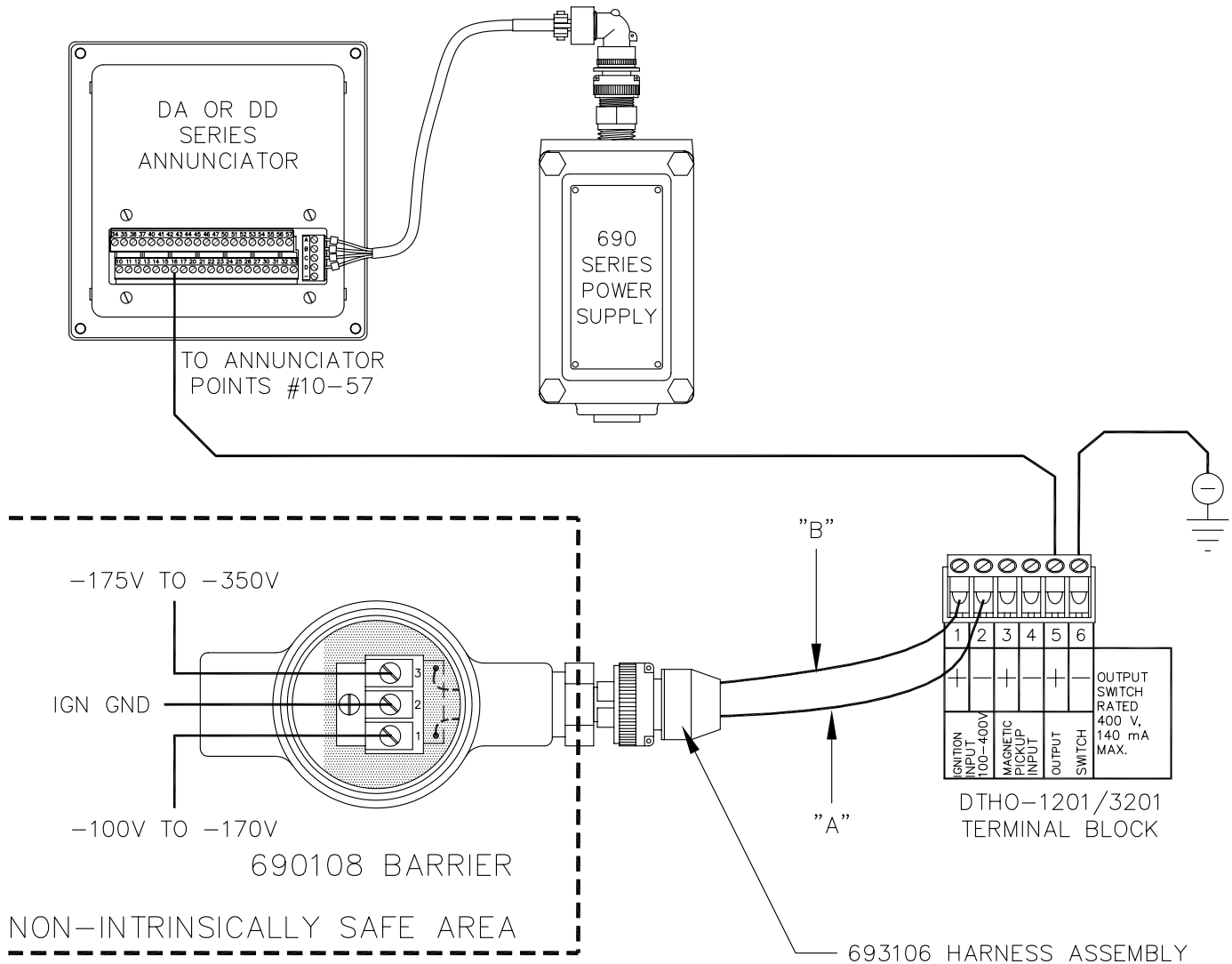

NOTES:

1. FOR CLASS I, DIV 1, GROUP D, INTRINSICALLY SAFE OPERATION, POWER THROUGH AN ALTRONIC 690108 ZENER BARRIER (FROM A CD IGNITION SHUTDOWN LEAD). FOLLOW ALL INSTRUCTIONS SUPPLIED WITH THE BARRIER. IF USED, CONNECT OUTPUT SWITCH TO DA OR DD SERIES ANNUNCIATOR WITH 690 SERIES POWER SUPPLY.

FIG. 7C DTHO-1201/3201 WIRING DIAGRAM INTRINSICALLY SAFE MAGNETIC PICKUP, 691118 SERIES

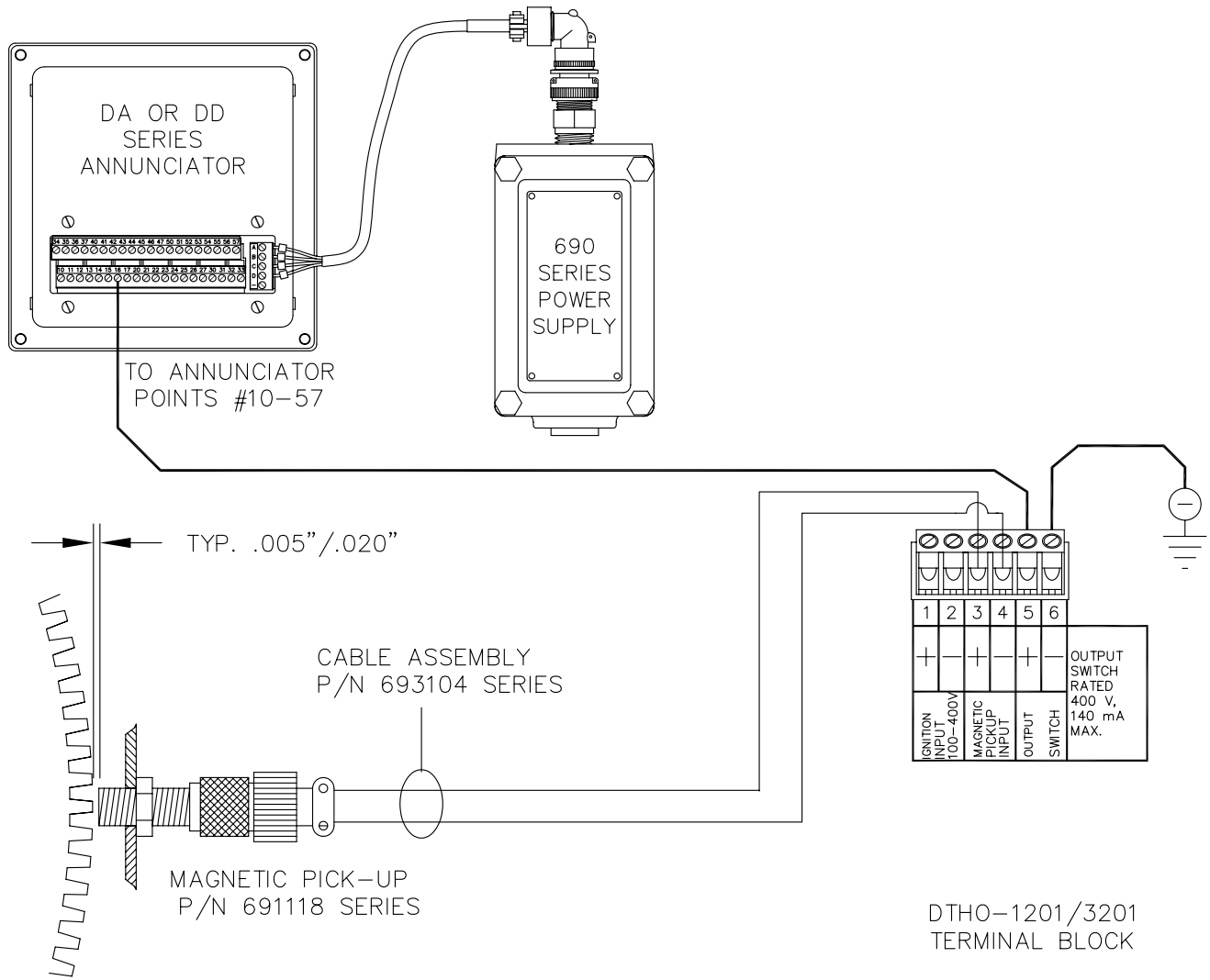

TYPICALLY
8 TO 20 PITCH GEAR

NOTES:

1. FOR INTRINSICALLY SAFE OPERATION, POWER THROUGH AN ALTRONIC 691118 SERIES MAGNETIC PICKUP.
2. CLASS I, DIV 1, GROUPS C & D WHEN OUTPUT SWITCH IS NOT USED. CLASS I, DIV 1, GROUP D WHEN CONNECTED TO 690 SERIES POWER SUPPLY AND DA OR DD SERIES ANNUNCIATOR.

FIG. 8 DTHO-1201/3201 WIRING DIAGRAM - DC RELAY

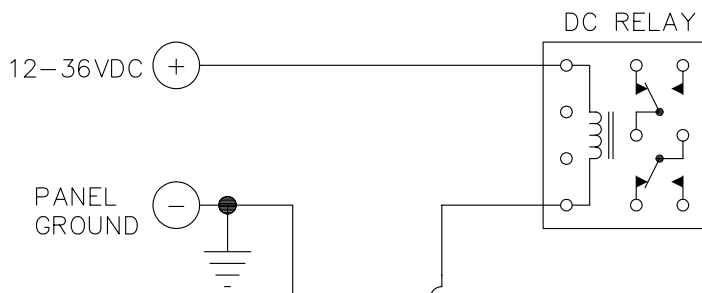

NOTES:

1. OUTPUT SWITCH IS RATED 400VDC, 140mA MAX.
2. OUTPUT SWITCH IS NON-LATCHING.

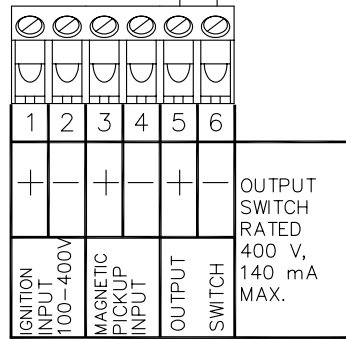
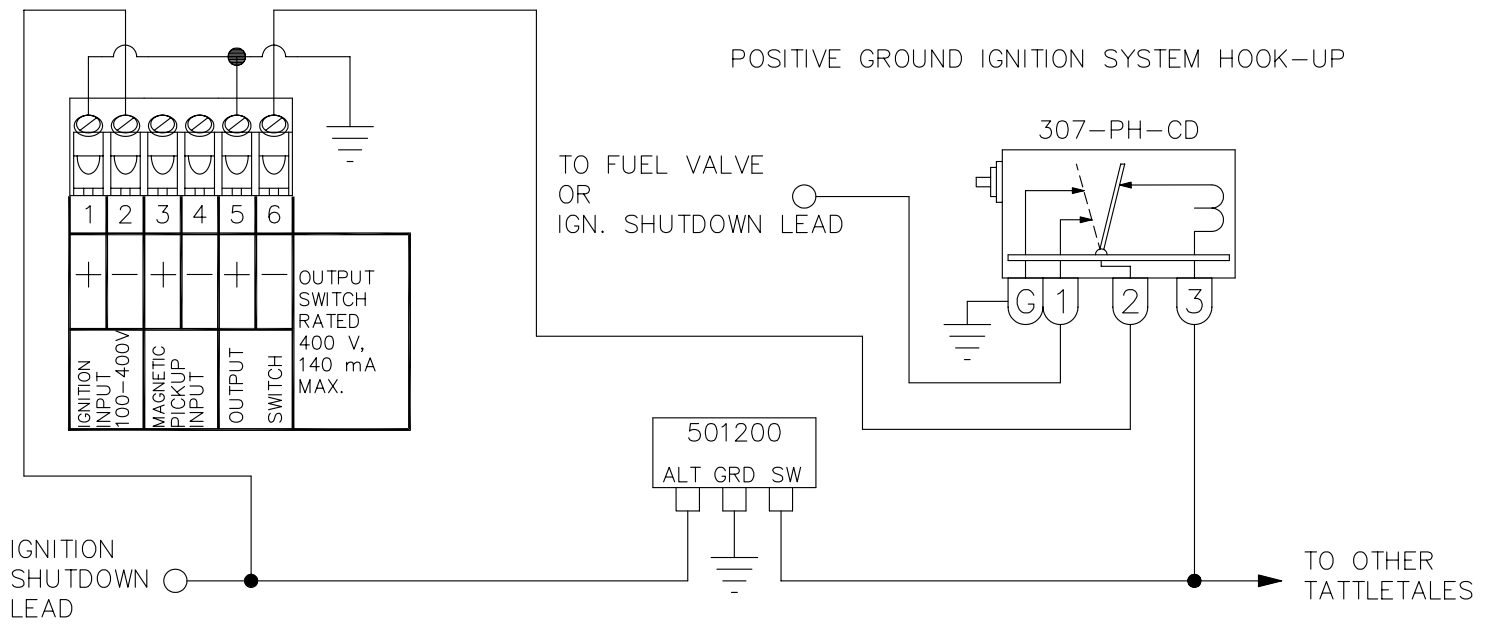
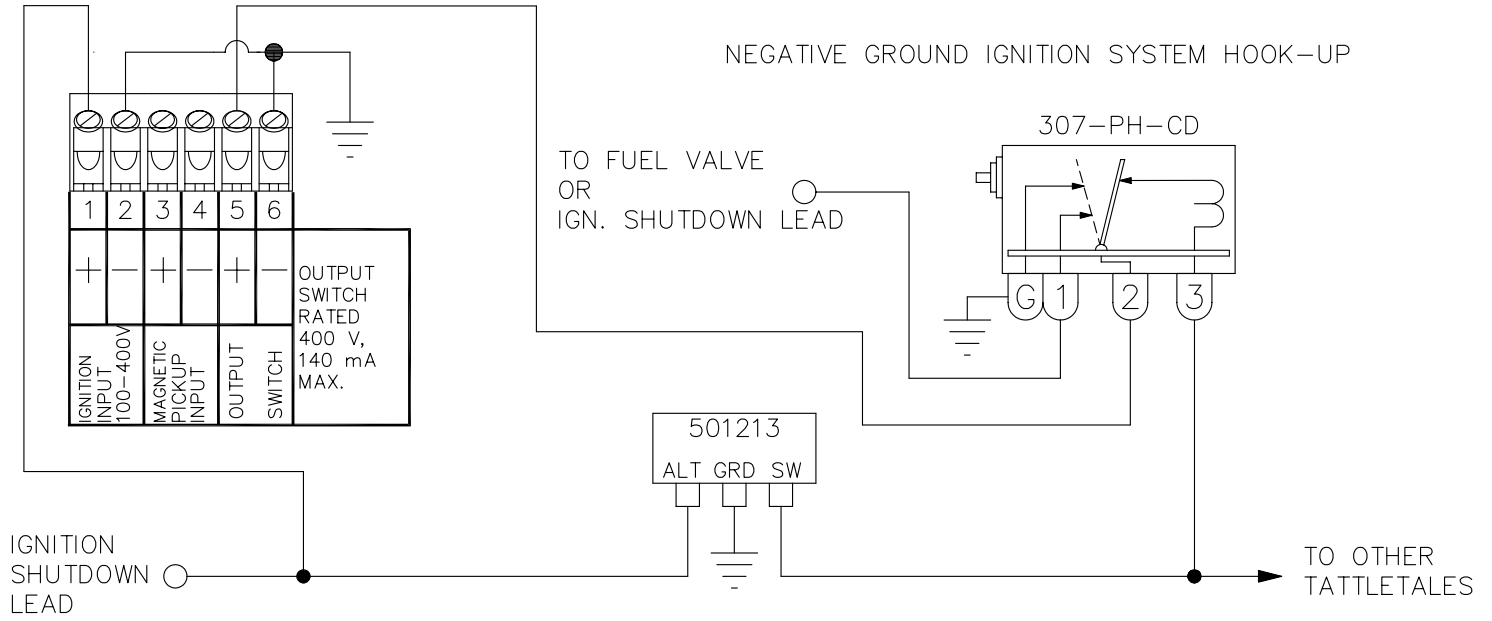

FIG. 9 DTHO-1201/3201 WIRING DIAGRAM – TATTLETALE



12-24VDC MURPHY TATTLETALE HOOK-UP

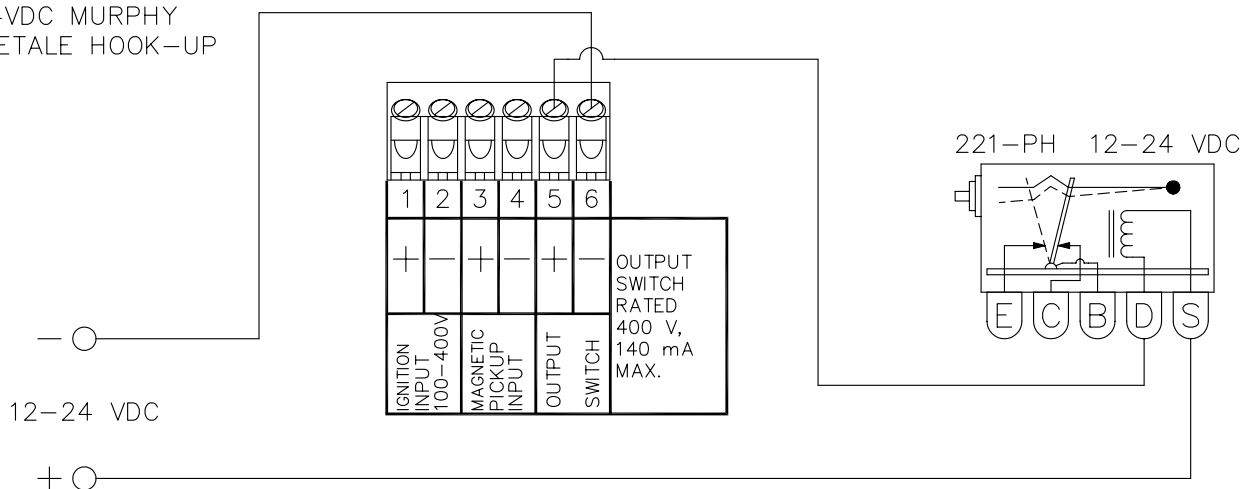

FIG. 10 DTHO-1201/3201 WIRING DIAGRAM - PNEUMATIC VALVE

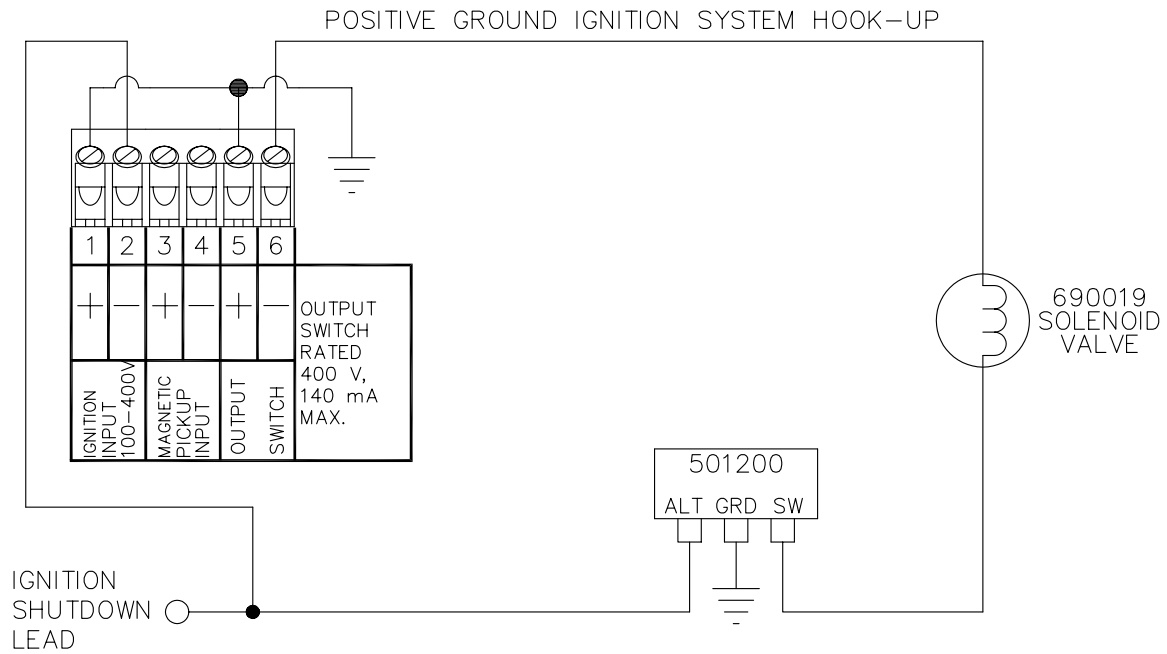
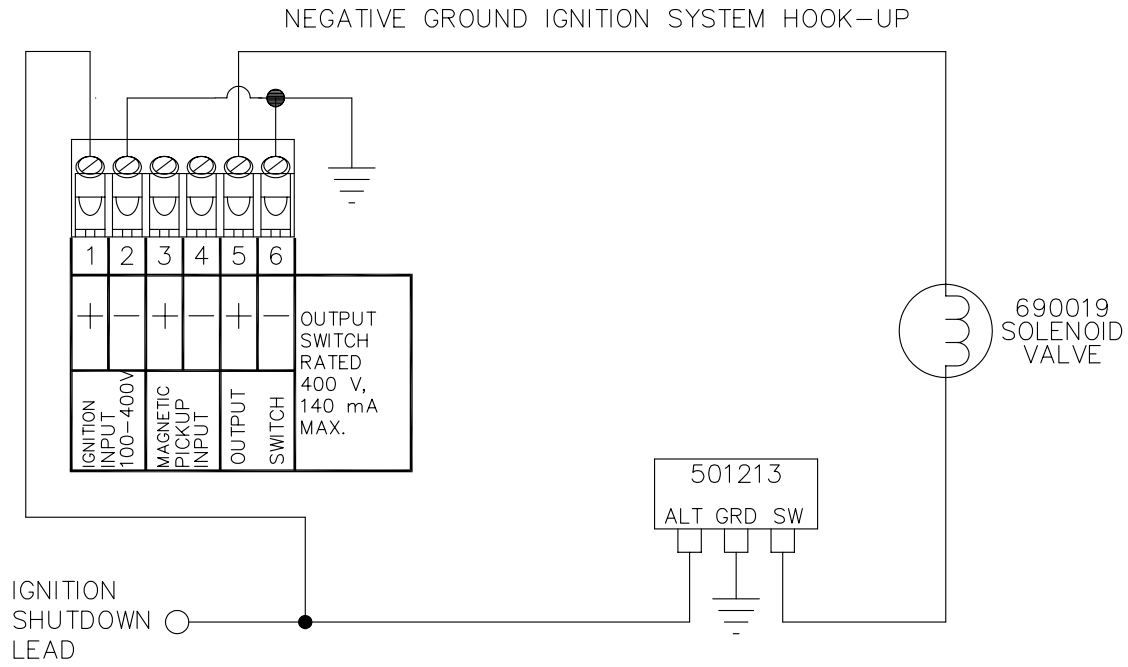
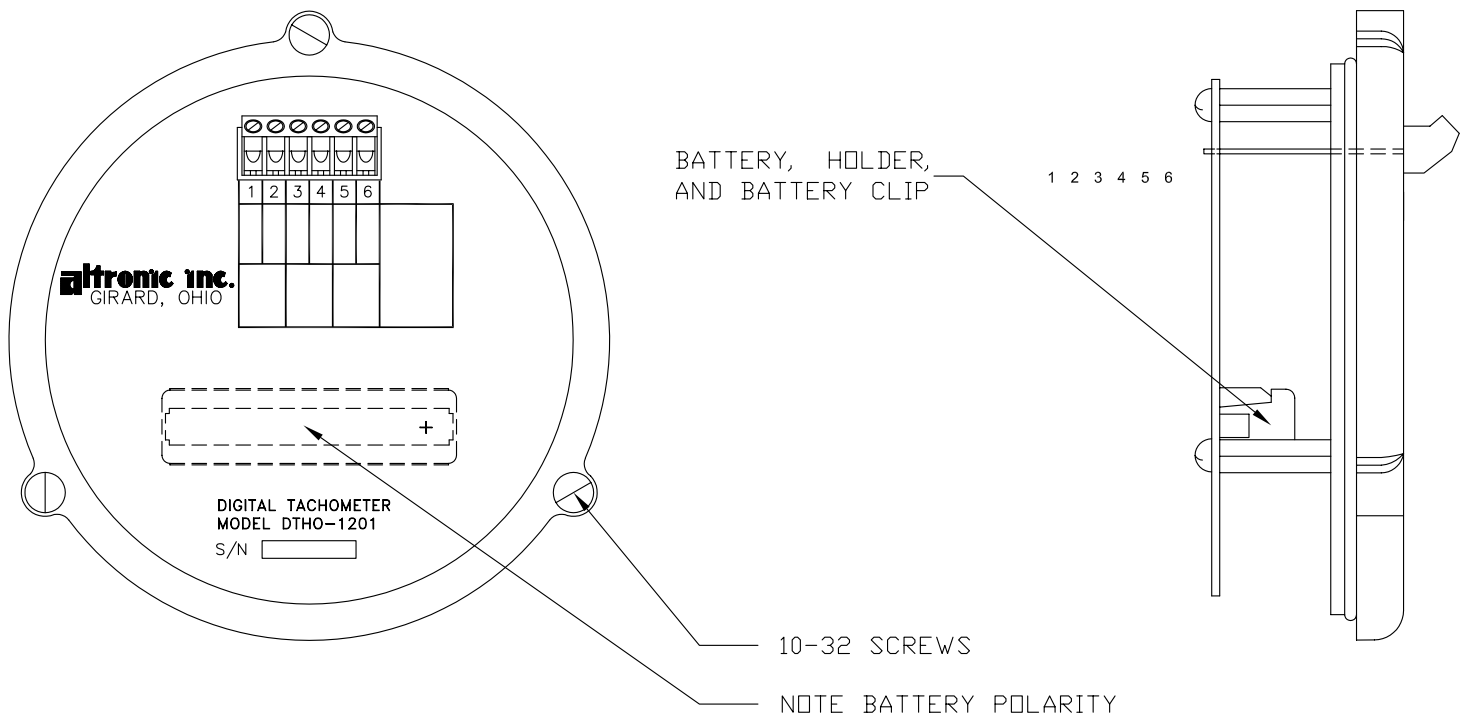

FIG. 11A DTHO-1201 BATTERY REPLACEMENT



WARNING. TO PREVENT IGNITION OF A HAZARDOUS ATMOSPHERE, BATTERIES MUST ONLY BE CHANGED IN AN AREA KNOWN TO BE NON-HAZARDOUS.

USE 1 EACH "AA" SIZE 3.6 VOLT HIGH ENERGY LITHIUM BATTERY, TADIRAN MODEL TL-5903/S, ALTRONIC P/N 601952.

NOTE: DO NOT USE A 1.5 VOLT "AA" SIZE BATTERY.

1. SEPARATE FRONT COVER FROM THE BACK HOUSING BY REMOVING THE (3) 10-32 SCREWS SHOWN.
2. LOCATE THE BATTERY, BATTERY HOLDER AND BATTERY CLIP, LOCATED ON THE BACK OF THE PCB.
3. REMOVE THE BATTERY CLIP FROM THE HOLDER.
4. REPLACE THE BATTERY, NOTING THE POLARITY INDICATED ON THE BACK VIEW OF TACHOMETER.
5. REPLACE BATTERY CLIP AND FRONT COVER.

FIG. 11B DTHO-3201 BATTERY REPLACEMENT

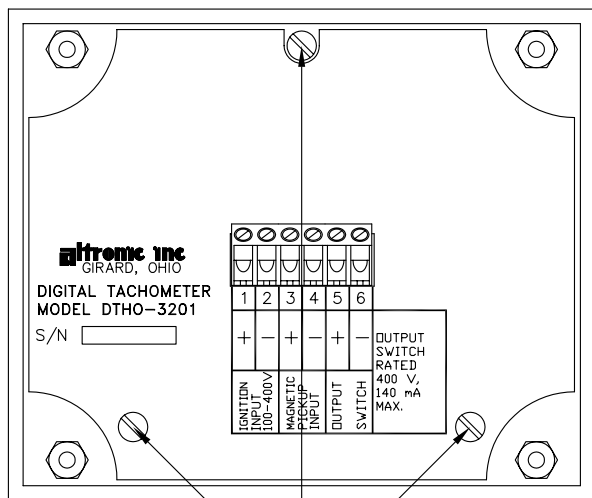

6-32 SCREWS

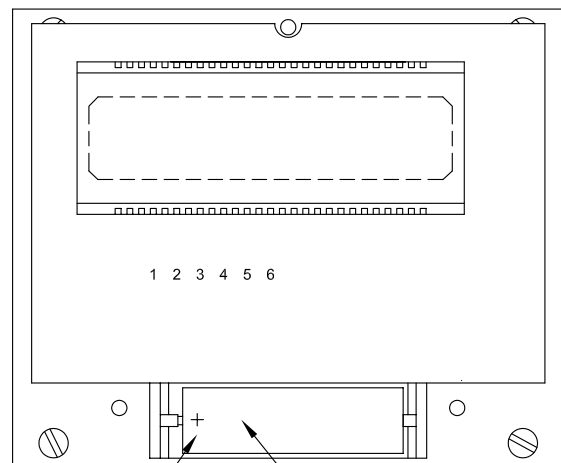

NOTE POLARITY

WARNING: TO PREVENT IGNITION OF A HAZARDOUS ATMOSPHERE, BATTERIES MUST ONLY BE CHANGED IN AN AREA KNOWN TO BE NON-HAZARDOUS.

USE 1 EACH "AA" SIZE 3.6 VOLT HIGH ENERGY LITHIUM BATTERY, TADIRAN MODEL TL-5903/S, ALTRONIC P/N 601952.

NOTE: DO NOT USE A 1.5 VOLT "AA" SIZE BATTERY.

1. SEPARATE FRONT COVER FROM THE BACK HOUSING BY REMOVING THE (3) 6-32 SCREWS SHOWN.
2. LOCATE THE BATTERY, BATTERY HOLDER AND BATTERY CLIP, LOCATED ON THE FRONT OF THE PCB.
3. REMOVE THE BATTERY CLIP FROM THE HOLDER.
4. REPLACE THE BATTERY, NOTING THE POLARITY INDICATED ON THE BACK VIEW OF TACHOMETER.
5. REPLACE THE BATTERY CLIP AND FRONT COVER.