

**ALTRONIC, INC.
712 TRUMBULL AVE.
GIRARD, OHIO 44420**

**ALTRONIC CPU-90 IGNITION SYSTEM
"E" VERSION**

APPLIES TO UNITS:

791 916-100

791 916-150

791 916-200

791 918-100

791 918-200

IMPORTANT SAFETY NOTICE

PROPER INSTALLATION, MAINTENANCE, REPAIR AND OPERATION OF THIS EQUIPMENT IS ESSENTIAL. THE RECOMMENDED PRACTICES CONTAINED HEREIN SHOULD BE FOLLOWED WITHOUT DEVIATION. AN IMPROPERLY INSTALLED OR OPERATING IGNITION SYSTEM COULD CAUSE PERSONAL INJURY TO OPERATORS OR OTHER NEARBY PERSONNEL.

TABLE OF CONTENTS**ALTRONIC CPU-90 SERVICE INSTRUCTIONS**

SECTION	ITEM	PAGE
1.0	SYSTEM DESCRIPTION	3
2.0	PARTS IDENTIFICATION AND SPECIFICATION	5
2.1	Parts List - CPU-90 Unit	5
3.0	TEST STAND REQUIREMENTS	6
4.0	TESTING PROCEDURE - CPU-90 UNIT	7
4.1	Voltage Output Test	7
4.2	Operational Test	7
5.0	TESTING PROCEDURE - HALL-EFFECT PICK-UP	7
5.1	Operational Test	7
6.0	OSCILLOSCOPE TESTING	8
6.1	Test Set-up	8
6.2	Storage Capacitor Voltage Pattern	8
7.0	TROUBLESHOOTING	9
8.0	BOARD REPLACEMENT PROCEDURE	9
8.1	Disassembly Procedure	9
8.2	Assembly Procedure	9

1.0 ALTRONIC CPU-90 - SYSTEM DESCRIPTION

The Altronic CPU-90 ignition system is a 12-24 VDC powered, microcircuit-based, capacitor discharge system. The system requires two signals from external magnetic pick-ups: (1) counts from a crankshaft-mounted gear (ring gear) or drilled holes in the engine flywheel; (2) a reset pulse once per revolution. A third pick-up (Hall-effect) is used to reference the compression stroke on 4-cycle applications.

Referring to the diagram below, the CPU-90 unit contains a logic/memory board and a power/distribution board. The power conversion circuitry steps up the 12-24 VDC input voltage to 150-180 volts (selectable) for the storage capacitor. The memory chip is programmed with the engine firing angle sequence and the number of reference teeth or holes. The logic circuit outputs precise trigger pulses to the solid state distributor board which routes the stored primary energy to the ignition coils in sequence.

The Altronic CPU-90 system implements timing changes by counting pulses from the reference teeth. The timing change increment is equal to $360/2N$ where N = the number of reference teeth or holes. With 180 teeth as recommended for test purposes, the timing change increment is one degree.

Five ways are provided to vary ignition timing:

- Manual timing adjustment with SW1, an internal 10-position switch
- Step-change timing adjustment set with SW2, a 16-position switch
- Control from an external 0-1,000 ohm potentiometer
- Control from an external 4-20 ma current loop signal
- Special memory chip with programmed curve vs. RPM

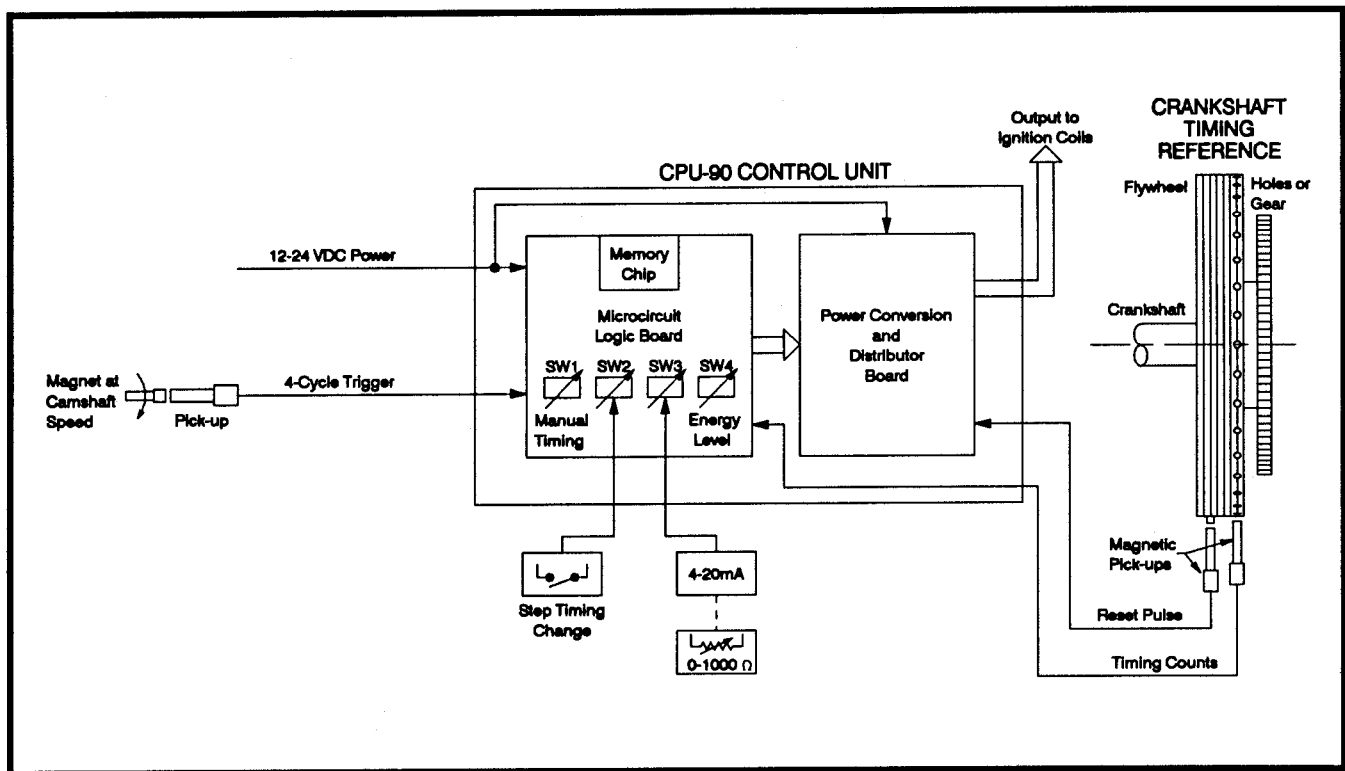

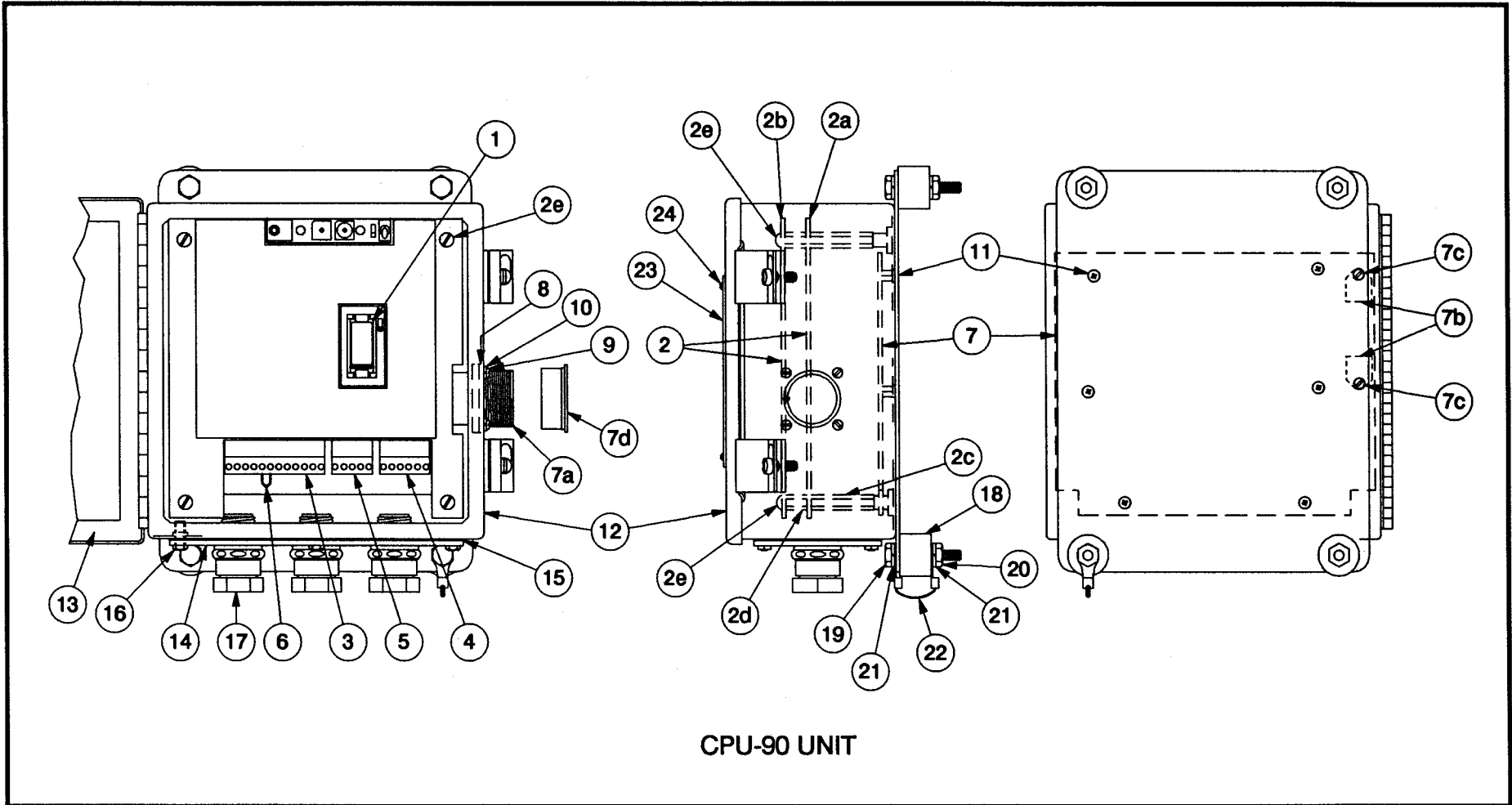

CPU-90 UNIT

2.0 PARTS IDENTIFICATION AND SPECIFICATION

2.1 PARTS LIST - CPU-90 UNIT: 781 916-100, 791 916-150, 791 916-200, 791 918-100, 791 918-200

FIGURE & REF. NO.	QTY.	PART NO.	DESCRIPTION
1	1	601 582	Memory chip
		601 582-S	Memory chip - non-standard
2	1	772 019-1R	Logic board retrofit assembly - 791 916-xxx unit
		772 019-2R	Logic board retrofit assembly - 791 918-xxx unit
2a	1	772 019-1	Logic board assembly - 791 916-xxx unit
		772 019-2	Logic board assembly - 791 918-xxx unit
2b	1	702 901	Shield board ass'y.
2c	4	610 523	Standoff 10-32 x 1.5
2d	4	610 254	Standoff 10-32 x .625
2e	4	902 439	Screw 10-32
3	1	204 014	Socket - 12-pin
4	1	204 015	Socket - 6-pin
5	1	204 016	Socket - 5-pin
6	1	503 242	Lead - jumper
7	1	781 041-16	Power/distribution board ass'y. - 791 916-200 unit
		781 041-18	Power/distribution board ass'y. - 791 918-200 unit
		781 043-16	Power/distribution board ass'y. - 791 916-100 unit
		781 043-16A	Power/distribution board ass'y. - 791 916-150 unit
		781 043-18	Power/distribution board ass'y. - 791 918-100 unit
7a	1	504 055-T	Connector
7b	2	610 193	Insulator
7c	2	902 595	Screw 6-32 plastic
7d	1	510 517	Cap - connector
8	1	501 222	Gasket - connector
9	4	902 064	Screw 6-32
10	4	901 000	Lockwasher #6
11	6	902 615	Seal screw 8-32
12	1	710 059	Enclosure
13	1	610 512	Gasket - cover
14	1	210 622	Plate - entry
15	1	210 625	Gasket - plate
16	6	902 599	Screw 10-24
17	3	510 527	Conduit fitting
18	4	610 165	Shock mount
19	4	902 593	Bolt 5/16-18
20	4	902 469	Nut 5/16-18
21	8	901 010	Lockwasher 5/16
22	1	610 386	Ground strap assembly
23	1	702 025A	Nameplate
24	4	902 578	Screw 4-40

3.0 TEST STAND REQUIREMENTS

- 3.1 In order to test an Altronic CPU-90 ignition system, a special test stand is required. Such a stand can be built starting with the elements of an ignition test stand suitable for a standard Altronic III system.
- 3.2 A standard ignition test stand includes these items:
- A. A variable speed motor of 0.5 HP or greater, capable of rotating 1,800 RPM.
 - B. Mounting adaptation to base or flange mount configuration.
 - C. A spark degree wheel graduated in 360 increments with the indicator attached to the shaft driving the Ignition unit.
 - D. Sixteen (16) ignition coils 501 061 connected to suitable, adjustable spark gaps. NOTE: The test stand should incorporate 18 ignition coils if 18-output units will be encountered.
- 3.3 The following items are additionally required to test the Altronic CPU-90 system.
- A. A source of gear tooth pulses mechanically connected to the motor drive; a 180 tooth gear is suggested.
 - B. A single reset pin (6-32 machine screw suggested) mounted to the face of the gear.
 - C. Magnetic pick-ups mounted to sense the gear teeth (A.) and reset pin (B.).
 - D. A primary wiring harness connecting the ignition coils to the CPU-90 unit. This requires connector MS3108A-22-14S - Altronic part no. 504 056.
 - E. A 581 602 manual control loop unit to simulate the 4-20ma control signal.
 - F. A DC power source capable of supplying 12-24VDC, 5 amps - see installation instructions form CPU-90 II, drawing 709 900. NOTE: If a battery is used to provide the DC power, be sure to install two fuses as shown on drawing 709 900.
 - G. An Altronic II alternator section; the standard Altronic II Test Unit may be used for this purpose. A distributor shaft assembly with 2:1 gear installed is required to properly test a 4-cycle application. The rotating magnet on the distributor shaft assembly must be over the Hall-effect switch when the Reset pin on the test stand is opposite its magnetic pick-up.
 - H. An Altronic II-CPU back cover assembly 281 500-1 or -2. Connect the wiring harness as shown below.
 - I. Test memory chips for 12-cylinder, 2-cycle and 16-cylinder, 4-cycle programmed with the number of teeth used on the test stand (usually 180). Examples: L2A180.EE and P4P180.ED.
 - J. A means to elevate the CPU-90 unit to a controlled temperature of 150° F. (65° C.).
- NOTE: Altronic Test Unit 791 025-1 can provide simulated pick-up signals to exercise the CPU-90 unit outputs at a fixed firing rate.

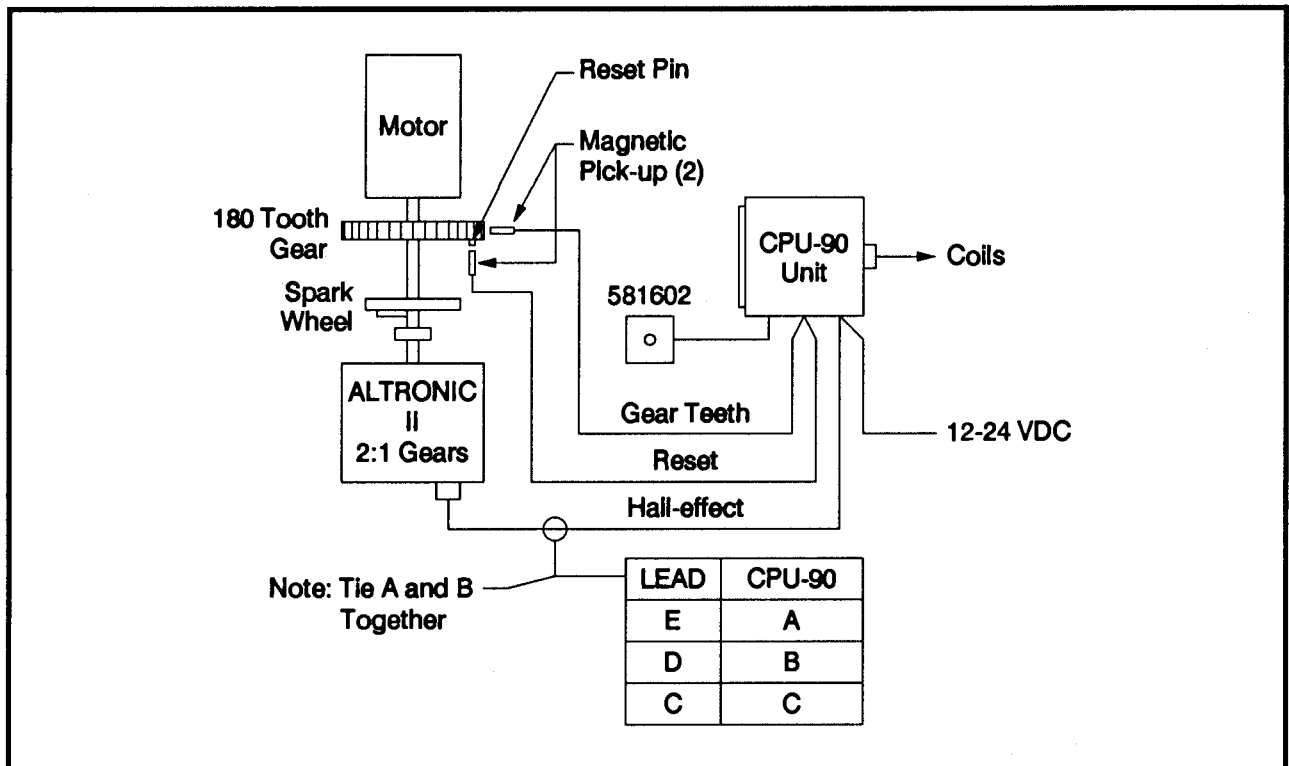

4.0 TESTING PROCEDURE - CPU-90 UNIT

- 4.1 VOLTAGE OUTPUT TEST - Connect a source of 12-24 VDC to the CPU-90 unit as shown in the Installation Instructions form CPU-90 II. Operate the test stand at 300 RPM leaving the 19-pin output connector disconnected. The voltage between the "G" pin (+) and the "N" pin (-) should be:
 With switch SW4 in the "HIGH" position: 150 ±10 VDC (180 ±10 VDC for unit 791 916-150)
 With switch SW4 in the "EX HIGH" position: 180 ±12 VDC (220 ±10 VDC for unit 791 916-150)
- 4.2 OPERATIONAL TEST - With the system completely connected, operate the test stand (180-tooth gear) at the speed indicated for each step. It is recommended that these tests be performed with the CPU-90 unit heated to a temperature of 150° F. (65°C.).

180 TOOTH GEAR RPM	TEST
75 RPM	All outputs fire a 15mm gap.
600 RPM	All outputs fire a 15mm gap.
1500 RPM	All outputs fire a 15mm gap.
1000 RPM	Each cylinder fires consistently in sequence; timing as follows starting with output "A" and proceeding in alphabetical sequence: Unit 791 916-xxx: A-B-C-D-E-F-K-L-M-N-P-R-S-T-U-V Unit 791 918-xxx: A-B-C-D-E-F-G-H-K-L-M-N-P-R-S-T-U-V Memory chip L2A180.EE (Cycle Jumper in 2-CYCLE position): 0-30-60-90-120-150-180-210-240-270-300-330
1500 RPM	Memory chip P4P180.ED (Cycle Jumper in 4-CYCLE position): 0-30-90-120-180-210-270-300-0-30-90-120-180-210-270-300
1500 RPM	Timing change on output "A". Timing switch SW1: 1 degree per switch step = 9 degrees total span Timing switch SW2: 1 degree per switch step = 15 degrees total span Analog Input timing control (SW3 in LOOP/POT. position): 16 degrees change from 4-20 ma signal or 0-1,000 ohm potentiometer NOTE: See drawing 709 905 in form CPU-90 II for hook-up detail.

NOTE: The 791 91x-200 units should fire a second spark on each output seven (7) degrees after the first spark at 1,000 RPM; this degree separation will vary with RPM.

5.0 TESTING PROCEDURE - HALL-EFFECT PICK-UP: 591 014-x

- 5.1 OPERATIONAL TEST - A source of 8-12 volts DC is required in addition to an ohmmeter. The DC source may be a small battery or a commercial power supply. Use one of the trigger magnets 260 604 or 720 002 and follow the test hook-up shown below.

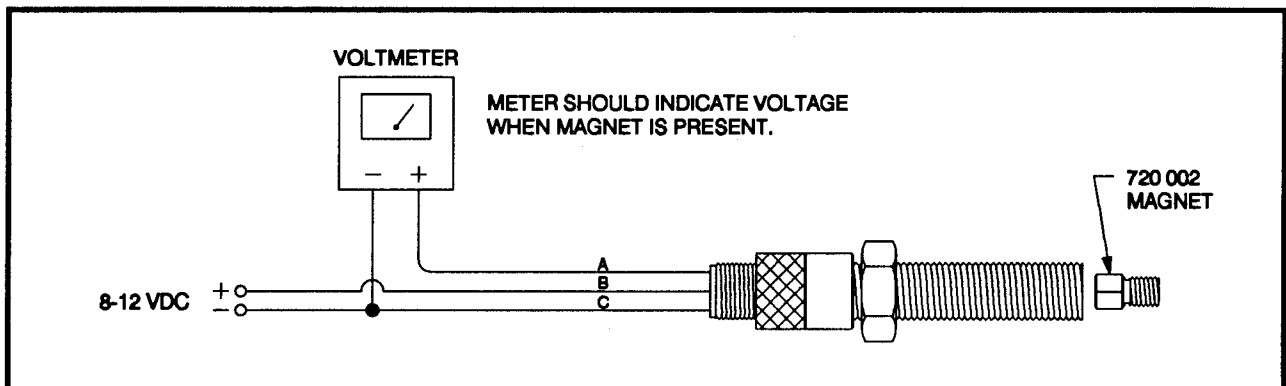

6.0 OSCILLOSCOPE TESTING (791 916-xxx UNITS ONLY)

6.1 TEST SET-UP - Two 100:1 oscilloscope probes are required. NOTE: The signals being monitored are 150-220 volts, positive polarity. The system should be completely connected and the test stand (180-tooth gear) operating at the speed indicated below. It is recommended that these tests be performed with the CPU-90 unit heated to a temperature of 150° F. (65° C.).

6.2 STORAGE CAPACITOR VOLTAGE PATTERN

- A. The trigger input of the oscilloscope should be connected to the "A" primary coil lead. NOTE: This is a 150-220 volt, positive polarity signal.
- B. Connect the oscilloscope probe to the "G" lead of the output connector. The CPU-90 system has a single storage capacitor; therefore all firings are seen on the "G" pin pattern. The normal capacitor patterns for the two recommended test memory chips are shown below for units 791 916-1xx with the output switch set as indicated.
- C. 791 916-200 units should show two (2) closely-spaced discharges for each single discharge indicated below.
- D. 791 918-xxx units do not have access to the storage capacitor; use tests of section 4.0.

791 916-100 (EX-HIGH)
791 916-150 (HIGH)
Memory L2A180.EE
800 RPM

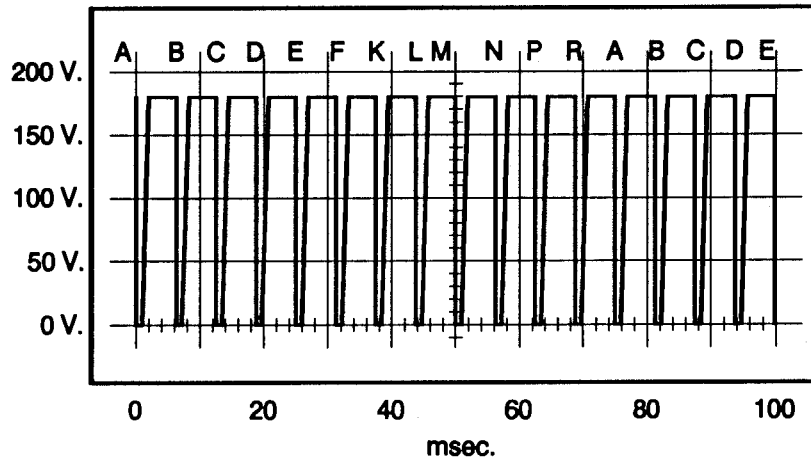

791 916-100 (EX-HIGH)
791 916-150 (HIGH)
Memory P4P180.ED
1200 RPM

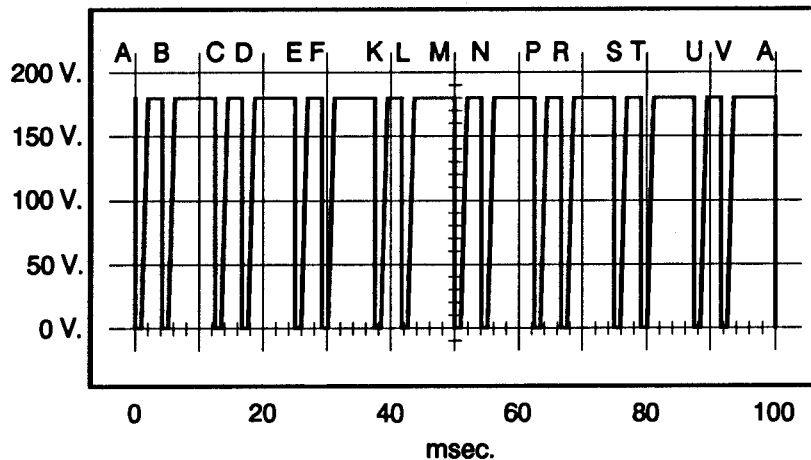

7.0 TROUBLESHOOTING

Perform all tests with at a test stand speed of 1000 RPM for a 2-cycle memory chip or 1500 RPM for a 4-cycle memory chip; make sure the Cycle Jumper is in the applicable position. The following chart assumes an adequate 12-24 VDC voltage source and properly installed magnetic pick-ups.

PROBLEM	TEST	TEST INDICATION	CORRECTIVE ACTION
No output	Section 4.1	Low voltage	Replace power/distribution board ass'y. (7)
No output	Section 6.2	0-50 VDC 150+ VDC	Replace power/distribution board ass'y. (7) Replace logic board ass'y. (2)
One output does not fire	Section 4.2 / 6.2	Missing discharge on stand or scope	Replace power/distribution board ass'y. (7)
Only one output fires or one output fires constantly	Section 4.2 / 6.2	One spark gap only is firing	Replace power/distribution board ass'y. (7)
Timing varies	Section 4.2	Timing other than as shown	Replace logic board ass'y. (2)

8.0 BOARD REPLACEMENT PROCEDURE

8.1 DISASSEMBLY PROCEDURE

- A. Loosen and remove four screws (2e) and shield board (2b). Remove four standoffs (2d). Tilt the logic board (2a) up at the entry plate end and carefully unplug the 4-pin connector at the bottom side of the board; then unplug the ribbon cable connector at the distribution board (7). The logic board assembly (2a) can now be removed.
- B. To remove the power/distribution board (7), remove four or six screws (11) and two plastic screws (7c). Then remove the four connector screws (9) and push connector (7a) back inside the box. The power/distribution board (7) can now be removed from the box.

8.2 ASSEMBLY PROCEDURE

- A. Check the condition of gaskets (8), (13), (15) and shock mounts (18); replace if necessary. Install new hardware where needed.
- B. Examine the insulator (7b) on the bottom of the two power transistors; replace if damaged.
- C. Set the power/distribution board (7) into place in the box. Install four or six NEW screws (11) and two NEW plastic screws (7c) into place loosely; then tighten starting first with screws (11). Install connector gasket (8) in place and insert connector (7a) through the hole with the keyway facing the open top of the box. Install screws (9) and lockwashers (10) and tighten securely.
- D. Make sure standoffs (2c) are tightened securely. Set the logic board assembly (2a) into place with the entry plate end tilted up to allow plugging in the ribbon cable connector to the distribution board (7). Then plug in the 4-pin connector on the bottom side of the logic board (2a) and set board in place over standoffs (2c). Install four standoffs (2d) and tighten securely. Install shield board (2b) in place and secure with four screws (2e).
- E. Retest the completely assembled unit per sections 4.0 and 6.0 to insure correct operation.