

**ALTRONIC CPU-90  
MEDIUM ENGINES, 2-18 CYLINDERS**

**APPLICATION LIST  
FORM CPU-90 AL 6-93**

The following items are required for each installation:

**A) ALTRONIC CPU-90 UNIT - 1 per system:**

Standard Units (shown in listing):

791 916-100 Standard unit, 16 outputs, 12-24 VDC Input

791 918-100 Standard unit, 18 outputs, 12-24 VDC Input

Optional Units (may be substituted as applicable):

791 916-150 Special coil unit, 16 outputs, 24 VDC Input (see no. 1 below)

791 916-200 Double-strike spark, 16 outputs, 24 VDC Input (see no. 2 below)

791 918-200 Double-strike spark, 18 outputs, 24 VDC Input (see no. 2 below)

OPTIONS:

1. Unit 791 916-150 is for use with Altronic II or Bendix Ignition coils.
2. Double-strike units may be applied to engines operating at or below 1,000 RPM - see listing.
3. For stainless steel enclosure, add suffix -SS to part no. Example: 791 916-100-SS

MEMORY PART NO. CODE (see listing):

PART NO. 791 91x-xx0 (abcdef.gh)

MEMORY NO. (abcdef.gh) Example: (L4A183.EE)

a) Letter of alphabet corresponding to no. of engine cylinders:

B = 2, C = 3, D = 4, E = 5, F = 6, G = 7, H = 8

I = 9, J = 10, L = 12, N = 14, P = 16, R = 18

b) Engine stroke-cycle:

2 = 2-cycle

4 = 4-cycle

c) Altronic firing pattern code:

A = even firing pattern

Other letter = odd firing pattern

def) No. of sensed teeth or holes:

Example: 183 = 183 teeth or holes

NOTE: The maximum number of teeth/holes permitted (N) is determined by the formula:

$$N = 45,000 / A \quad \text{where } A = \text{the largest firing angle interval in degrees}$$

g) Memory series code:

E = CPU-90 series

h) Timing range code:

D = 16 degrees, 4-cycle; 8 degrees, 2-cycle

E = 24 degrees, 4-cycle; 16 degrees, 2-cycle

S = special range or curve

R = curve vs. RPM

EXAMPLES:

8-Cylinder, 4-Cycle Engine

60° - 120° odd firing pattern

183 sensed teeth

24 degree range on 4-20 ma loop

PART NO. 791 916-100 (H4B183.EE)

6-Cylinder, 2-Cycle Engine

60° even firing pattern

318 sensed teeth

16 degree range on 4-20 ma loop

PART NO. 791 916-100 (F2A318.EE)

**ALTRONIC CPU-90  
MEDIUM ENGINES, 2-18 CYLINDERS**

**APPLICATION LIST  
FORM CPU-90 AL 6-93**

---

**B) HARNESS ASSEMBLY, CPU-90 UNIT TO IGNITION COILS - 1 per system:**

793 012-8	Unshielded, 180°, 8 outputs
793 012-12	Unshielded, 180°, 12 outputs
793 012-16	Unshielded, 180°, 16 outputs
793 015-8	Shielded, 180°, 48" conduit, 8 outputs
793 015-12	Shielded, 180°, 48" conduit, 12 outputs
793 015-16	Shielded, 180°, 48" conduit, 16 outputs
793 022-8	Shielded, 180°, 84" conduit, 8 outputs
793 022-12	Shielded, 180°, 84" conduit, 12 outputs
793 022-16	Shielded, 180°, 84" conduit, 16 outputs
793 023-8	Shielded, 90°, 48" conduit, 8 outputs
793 023-9	Shielded, 90°, 48" conduit, 9 outputs
793 023-12	Shielded, 90°, 48" conduit, 12 outputs
793 023-16	Shielded, 90°, 48" conduit, 16 outputs
793 023-18	Shielded, 90°, 48" conduit, 18 outputs
793 024-8	Shielded, 90°, 84" conduit, 8 outputs
793 024-12	Shielded, 90°, 84" conduit, 12 outputs
793 024-16	Shielded, 90°, 84" conduit, 16 outputs

**C) MAGNETIC PICK-UP, 5/8"-18 THREAD - 2 per system:**

691 118-1	1.75" threaded body length
691 118-2	2.50" threaded body length
691 118-3	3.00" threaded body length
691 118-4	4.50" threaded body length
691 118-6	6.00" threaded body length

**D) CABLE ASSEMBLY, MAGNETIC PICK-UP - 2 per system:**

593 048-24	Shielded, 180°, 24" conduit
593 048-36	Shielded, 180°, 36" conduit
593 048-48	Shielded, 180°, 48" conduit
593 048-72	Shielded, 180°, 72" conduit
593 048-96	Shielded, 180°, 96" conduit
593 054-24	Shielded, 90°, 24" conduit
593 054-36	Shielded, 90°, 36" conduit
593 054-48	Shielded, 90°, 48" conduit
593 054-72	Shielded, 90°, 72" conduit
593 054-96	Shielded, 90°, 96" conduit
693 104-1	Unshielded, 10 ft. cable
693 104-2	Unshielded, 20 ft. cable
693 104-3	Unshielded, 30 ft. cable
693 104-4	Unshielded, 40 ft. cable
693 104-5	Unshielded, 50 ft. cable

- E) CYCLE TRIGGER (4-CYCLE ENGINES ONLY) - 1 of each item per system:**
- 260 604 Trigger magnet, 5/8" dia., 8 mm thread (use up to 15" diameter rotating circle)
  - 720 002 Trigger magnet, 1/4" dia., 8 mm thread (use up to 6" diameter rotating circle)
  - 790 111-1 Magnet disc, 5.0" dia. (use with kit 790 005 on Caterpillar engines, see note 4)
  - 591 014-2 Hall-effect pick-up, 2.5" threaded bushing length
  - 591 014-4 Hall-effect pick-up, 4.5" threaded bushing length
  - 593 050 Pick-up cable assembly, unshielded
  - 593 052-12 Pick-up cable assembly, shielded, 12" conduit
  - 593 052-18 Pick-up cable assembly, shielded, 18" conduit
  - 593 052-24 Pick-up cable assembly, shielded, 24" conduit
  - 593 052-36 Pick-up cable assembly, shielded, 36" conduit
- F) IGNITION COIL - 1 per spark plug:**
- 501 061 Unshielded, standard duration
  - 591 010 Unshielded, long duration
  - 591 040 Unshielded, long duration (do not use with 791 91x-200 units)
  - 501 061-S Shielded, standard duration
  - 591 010-S Shielded, long duration
  - 591 012 Shielded, long duration, flange mount
  - 591 007 Integral, 1"-20 thread x 5.6" lg.
  - 591 011A Integral, 13/16"-20 thread x 6.1" lg.
  - 591 011B Integral, 13/16"-20 thread x 10.8" lg.

**NOTE:** Unit 791 916-150 may be used with Altronic 291 001, 291 001-S, 591 008 and Bendix ignition coils.

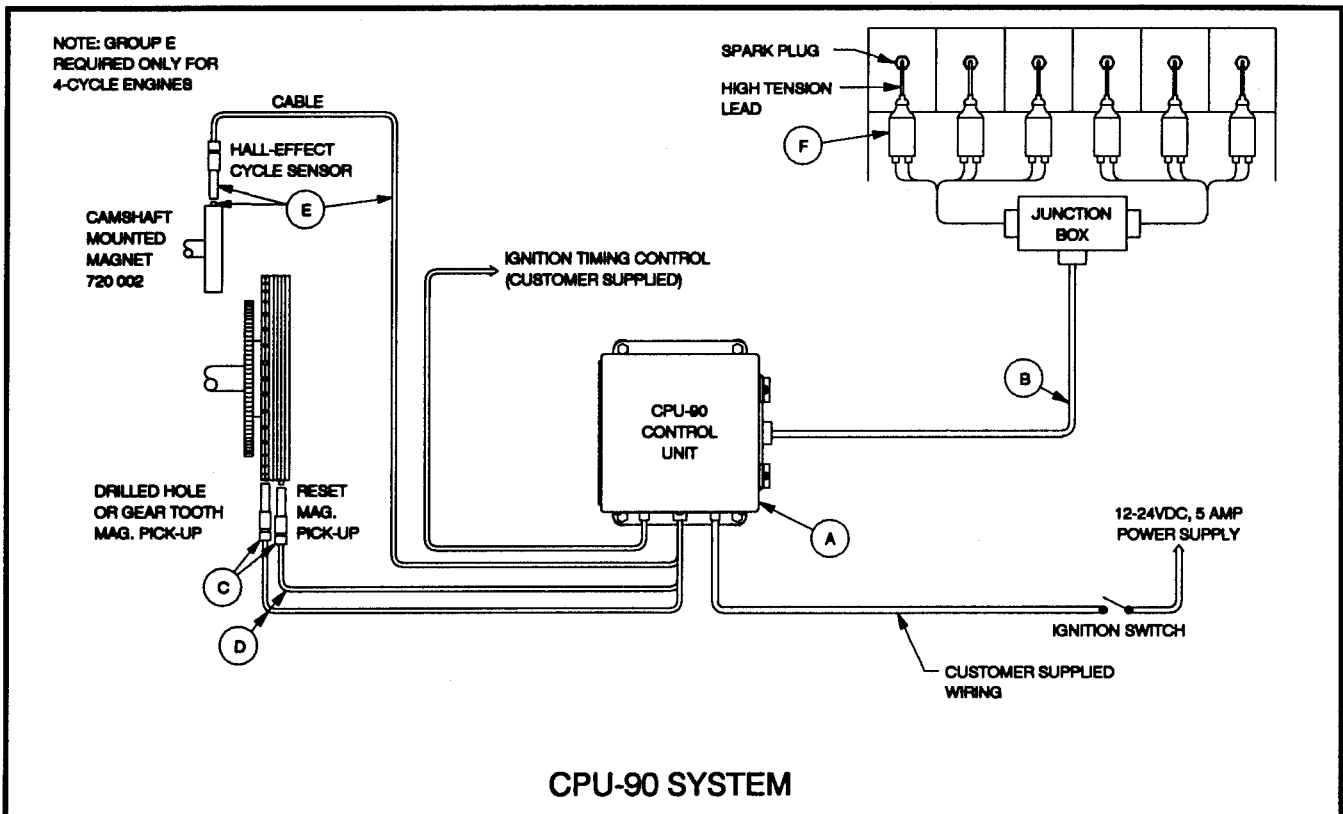

**ALTRONIC CPU-90  
MEDIUM ENGINES, 2-18 CYLINDERS**

**APPLICATION LIST  
FORM CPU-90 AL 6-93**

<b>ENGINE / MODEL NO.</b>	<b>FIRING PATTERN</b>	<b>CPU-90 UNIT NO.</b>	<b>MEMORY CODE NO.</b>	<b>QTY. COILS</b>	<b>NOTES</b>	
<b>BERGEN</b>						
KRGS-6	120°	791 918-100	F4A180.EE	6	1	
KRGS-8	90°	791 918-100	H4A180.EE	8	1	
KRGS-9	80°	791 918-100	I4A180.EE	9	1	
KVGS-12	50° - 70°	791 918-100	L4V180.ED	12	1	
KVGS-16	50° - 40°	791 918-100	P4V180.ED	16	1	
KVGS-18	10° - 70°	791 918-100	R4T180.ED	18	1	
<b>BRONS (MAN)</b>						
12V20/31NG	75° - 45°	791 918-100	L4C252.ED	12	1	
14V20/31NG	57.86° - 45°	791 918-100	N4C252.ED	14	1	
16V20/31NG	45°	791 918-100	P4A252.ED	16	1	
18V20/31NG	35° - 45°	791 918-100	R4C252.ED	18	1	
<b>CATERPILLAR</b>						
3406SI	120°	791 916-100	F4A113.EE	6	1	
3408SI	90°	791 916-100	H4A136.EE	8	1	
3412SI	55° - 65°	791 916-100	L4P136.EE	12	1	
3508SI	90°	791 916-100	H4A183.EE	8	1	
3512SI	60°	791 916-100	L4A183.EE	12	1	
3516SI	30° - 60°	791 916-100	P4P183.EE	16	1	
G379	60° - 120°	791 916-100	H4B183.EE	8	1,4	
G398	60°	791 916-100	L4A183.EE	12	1,4	
G399	30° - 60°	791 916-100	P4P183.EE	16	1,4	
<b>CLARK</b>						
BA, HBA, HLA	- 5	72°	791 916-100	E2Axxx.EE	10	2,3
	- 6	60°	791 916-100	F2Axxx.EE	12	2,3
	- 8	22.5° - 67.5°	791 916-100	H2Hxxx.EE	16	2,3
	- 10	36°	791 916-100	J2Axxx.EE	20	2,3
MA, HMA, HMB, TMB	- 4	90°	791 916-100	D2Axxx.EE	4,8	2,3
	- 6	60°	791 916-100	F2Axxx.EE	6,12	2,3
	- 8	22.5° - 67.5°	791 916-100	H2Hxxx.EE	8,16	2,3
	- 10	36°	791 916-100	J2Axxx.EE	10,20	2,3
RA, HRA	- 32	120°	791 916-100	C2Axxx.EE	6	2,3
	- 4	90°	791 916-100	D2Axxx.EE	8	2,3
	- 5	72°	791 916-100	E2Axxx.EE	10	2,3
	- 6	60°	791 916-100	F2Axxx.EE	12	2,3
	- 8	45°	791 916-100	H2Axxx.EE	16	2,3
TVM	- 10	22° - 50°	791 916-100	J2Txxx.EE	20	2,3
	- 12	10° - 50°	791 916-100	L2Txxx.EE	24	2,3

**ALTRONIC CPU-90  
MEDIUM ENGINES, 2-18 CYLINDERS**

**APPLICATION LIST  
FORM CPU-90 AL 6-93**

ENGINE / MODEL NO.	FIRING PATTERN	CPU-90 UNIT NO.	MEMORY CODE NO.	QTY. COILS	NOTES
<b>COOPER BESSEMER</b>					
GMV (short stroke) - 4	63° - 117°	791 916-100	D2Fxxx.EE	4	2,3
GMX series - 6	63° - 57°	791 916-100	F2Fxxx.EE	6	2,3
	27° - 63°	791 916-100	H2Fxxx.EE	8	2,3
	9° - 63°	791 916-100	J2Fxxx.EE	10	2,3
GMV, GMVA, GMVC, GMVE - 4	60° - 120°	791 916-100	D2Bxxx.EE	4,8	2,3
	60°	791 916-100	F2Axxx.EE	6,12	2,3
	30° - 60°	791 916-100	H2Bxxx.EE	8,16	2,3
	12° - 60°	791 916-100	J2Bxxx.EE	10,20	2,3
GMW, GMWA, GMWC, GMWE - 6	36° - 84°	791 916-100	F2Dxxx.EE	12	2,3
	36° - 54°	791 916-100	H2Dxxx.EE	16	2,3
	36°	791 916-100	J2Axxx.EE	20	2,3
	24° - 36°	791 916-100	L2Dxxx.EE	24	2,3
<b>INGERSOLL RAND</b>					
KVG, KVGR - 26	165° - 75°	791 916-100	F4Cxxx.EE	6	2
	165° - 75°	791 916-100	F4Cxxx.EE	6	2
	90° - 90° - 90° - 135° - 90° - 90° - 90° - 45°	791 916-100	H4Exxx.EE	8	2
	90° - 135° - 45° - 135° - 90° - 45° - 135° - 45°	791 916-100	H4Kxxx.EE	8	2
	165° - 75°	791 916-100	F4Cxxx.EE	6	2
	45° - 135°	791 916-100	H4Hxxx.EE	8	2
	90° - 90° - 90° - 135° - 90° - 90° - 90° - 45°	791 916-100	H4Exxx.EE	8	2
	27° - 117°	791 916-100	J4Exxx.EE	10	2
	27° - 117°	791 916-100	J4Exxx.EE	10	2
	45° - 75°	791 916-100	L4Hxxx.EE	12	2
	27° - 117°	791 916-100	J4Exxx.EE	10	2
	45° - 75°	791 916-100	L4Hxxx.EE	12	2
	45° - 75°	791 916-100	L4Hxxx.EE	12	2
	45° - 75°	791 916-100	L4Hxxx.EE	12	2
	KVS, KVSR - 36	165° - 75°	791 916-100	F4Cxxx.EE	12
90° - 135° - 45° - 135° - 90° - 45° - 135° - 45°		791 916-100	H4Kxxx.EE	16	2
45° - 75° - 45° - 75° - 120° - 45° - 75° - 45° - 75° - 120°		791 916-100	J4Sxxx.EE	20	2
45° - 75°		791 916-100	L4Hxxx.EE	24	2
45° - 75°		791 916-100	L4Hxxx.EE	24	2
PKVG, PKVGR - 6	165° - 75°	791 916-100	F4Cxxx.EE	6	2
	90° - 90° - 90° - 135° - 90° - 90° - 90° - 45°	791 916-100	H4Exxx.EE	8	2
	27° - 117°	791 916-100	J4Exxx.EE	10	2
	45° - 75°	791 916-100	L4Hxxx.EE	12	2

INGERSOLL RAND LISTING CONTINUED ON NEXT PAGE

**ALTRONIC CPU-90  
MEDIUM ENGINES, 2-18 CYLINDERS**

**APPLICATION LIST  
FORM CPU-90 AL 6-93**

ENGINE / MODEL NO.	FIRING PATTERN	CPU-90 UNIT NO.	MEMORY CODE NO.	QTY. COILS	NOTES
--------------------	----------------	-----------------	-----------------	------------	-------

**INGERSOLL RAND (continued)**

PKVS, PKVSR	- 6	165° - 75°	791 916-100	F4Cxxx.EE	12	2
	- 8	90° - 135° - 45° - 135° - 90° - 45° - 135° - 45°	791 916-100	H4Kxxx.EE	16	2
	- 10	45° - 75° - 45° - 75° - 120° - 45° - 75° - 45° - 75° - 120°	791 916-100	J4Sxxx.EE	20	2
	- 12	45° - 75°	791 916-100	L4Hxxx.EE	24	2
PSVG	- 6	185° - 55°	791 916-100	F4Pxxx.EE	6	2
	- 8	90° - 90° - 90° - 65° - 90° - 90° - 90° - 115°	791 916-100	H4Pxxx.EE	8	2
	- 10	7° - 137°	791 916-100	J4Pxxx.EE	10	2
	- 12	55° - 65°	791 916-100	L4Pxxx.EE	12	2
PVG, XVG	- 4	180° - 240° - 180° - 120°	791 916-100	D4Gxxx.EE	4	2
	- 6	60° - 180° - 120° - 60° - 120° - 180°	791 916-100	F4Exxx.EE	6	2
	- 8	60° - 120°	791 916-100	H4Bxxx.EE	8	2
SVG	- 6	180° - 60°	791 916-100	F4Bxxx.EE	6	2
	- 8	90° - 90° - 90° - 60° - 90° - 90° - 90° - 120°	791 916-100	H4Gxxx.EE	8	2
	- 10	12° - 132°	791 916-100	J4Dxxx.EE	10	2
	- 12	60°	791 916-100	L4Axxx.EE	12	2

**M.E.P.**

M.E.P.	- 6	60°	791 916-100	F2A318.EE	12	1,3
	- 8	45°	791 916-100	H2A318.EE	16	1,3
	- 10	36°	791 916-100	J2A318.EE	20	1,3
	- 12	30°	791 916-100	L2A318.ED	24	1,3

**RUSTON**

12RK270G	75° - 45°	791 916-100	L4C292.ED	24	1
16RK270G	45°	791 916-100	P4A292.ED	32	1

**SUPERIOR**

6G825	120°	791 916-100	F4A230.EE	6	1
6GT825	120°	791 916-100	F4A230.EE	6	1
6GTL	120°	791 916-100	F4A230.EE	6	1
6GTLA	120°	791 916-100	F4A230.ER1	6	1
6GTLB	120°	791 916-100	F4A230.ER1	6	1
8G825	90°	791 916-100	H4A230.EE	8	1
8GT825	90°	791 916-100	H4A230.EE	8	1
8GTL	90°	791 916-100	H4A230.EE	8	1
8GTLA	90°	791 916-100	H4A230.ER1	8	1
8GTLB	90°	791 916-100	H4A230.ER1	8	1
8SGTB	90°	791 916-100	H4A230.ER7	8	1

SUPERIOR LISTING CONTINUED ON NEXT PAGE

**ALTRONIC CPU-90  
MEDIUM ENGINES, 2-18 CYLINDERS**

**APPLICATION LIST  
FORM CPU-90 AL 6-93**

ENGINE / MODEL NO.	FIRING PATTERN	CPU-90 UNIT NO.	MEMORY CODE NO.	QTY. COILS	NOTES
<b>SUPERIOR (continued)</b>					
12G825	48° - 72°	791 916-100	L4D276.EE	12	1,5
12GT825	48° - 72°	791 916-100	L4D276.EE	12	1,5
12GTL	48° - 72°	791 916-100	L4D276.EE	12	1,5
12GTLA	48° - 72°	791 916-100	L4D276.ER1	12	1
12GTLB	48° - 72°	791 916-100	L4D276.ER1	12	1
12SGT	48° - 72°	791 916-100	L4D276.EE	12	1,5
12SGTA	48° - 72°	791 916-100	L4D276.ER1	12	1
12SGTB	48° - 72°	791 916-100	L4D276.ER1	12	1
16G825	48° - 42°	791 916-100	P4G276.EE	16	1,5
16GT825	48° - 42°	791 916-100	P4G276.EE	16	1,5
16GTL	48° - 42°	791 916-100	P4G276.EE	16	1,5
16GTLA	48° - 42°	791 916-100	P4G276.ER1	16	1
16GTLB	48° - 42°	791 916-100	P4G276.ER1	16	1
16SGT	48° - 42°	791 916-100	P4G276.EE	16	1,5
16SGTA	48° - 42°	791 916-100	P4G276.ER1	16	1
16SGTB	48° - 42°	791 916-100	P4G276.ER1	16	1

**WAUKESHA**

F2895G	120°	791 916-100	F4A208.EE	6	1
F2895GL	120°	791 916-100	F4A208.EE	6	1
F2895GSI	120°	791 916-100	F4A208.EE	6	1
F3521G	120°	791 916-100	F4A208.EE	6	1
F3521GL	120°	791 916-100	F4A208.EE	6	1
F3521GSI	120°	791 916-100	F4A208.EE	6	1
L5108G	60°	791 916-100	L4A208.EE	12	1
L5108GL	60°	791 916-100	L4A208.EE	12	1
L5108GSI	60°	791 916-100	L4A208.EE	12	1
L5790G	60°	791 916-100	L4A208.EE	12	1
L5790GL	60°	791 916-100	L4A208.EE	12	1
L5790GSI	60°	791 916-100	L4A208.EE	12	1
L7042G	60°	791 916-100	L4A208.EE	12	1
L7042GL	60°	791 916-100	L4A208.EE	12	1
L7042GSI	60°	791 916-100	L4A208.EE	12	1
P9390G	30° - 60°	791 916-100	P4P208.EE	16	1
P9390GL	30° - 60°	791 916-100	P4P208.EE	16	1
P9390GSI	30° - 60°	791 916-100	P4P208.EE	16	1

**ALTRONIC CPU-90  
MEDIUM ENGINES, 2-18 CYLINDERS**

**APPLICATION LIST  
FORM CPU-90 AL 6-93**

ENGINE / MODEL NO.	FIRING PATTERN	CPU-90 UNIT NO.	MEMORY CODE NO.	QTY. COILS	NOTES	
<b>WORTHINGTON</b>						
LTC	- 3	120°	791 916-100	C2Axxx.EE	6	2,3
	- 4	90°	791 916-100	D2Axxx.EE	8	2,3
	- 5	72°	791 916-100	E2Axxx.EE	10	2,3
	- 6	60°	791 916-100	F2Axxx.EE	12	2,3
	- 8	45°	791 916-100	H2Axxx.EE	16	2,3
SLHC	- 5	144°	791 916-100	E4Axxx.EE	10	2
	- 6	120°	791 916-100	F4Axxx.EE	12	2
	- 7	102.86°	791 916-100	G4Axxx.EE	14	2
	- 8	90°	791 916-100	H4Axxx.EE	16	2
	- 10	72°	791 916-100	J4Axxx.EE	20	2
UTC	- 5	72°	791 916-100	E2Axxx.EE	10	2,3
	- 6	60°	791 916-100	F2Axxx.EE	12	2,3
	- 7	51.43°	791 916-100	G2Axxx.EE	14	2,3
	- 8	45°	791 916-100	H2Axxx.EE	16	2,3
	- 10	36°	791 916-100	J2Axxx.EE	20	2,3

**NOTES:**

- 1 - Memory listed is for standard engine ring gear. If a different number of teeth/holes are to be sensed, the memory code no. must be changed accordingly.
- 2 - Contact the factory for engine models not listed. When ordering, the number of sensed teeth/holes must be specified in place of "xxx" in the listing.  
NOTE: The maximum number of teeth/holes permitted (N) is determined by the formula:  
$$N = 45,000 / A \quad \text{where } A = \text{the largest firing interval in degrees}$$
- 3 - 2-cycle application; CPU-90 unit 791 916-200 with double-strike spark feature recommended for maximum performance.
- 4 - Mounting adaptor kit 790 005 available; use with disc 790 111-1 for cycle trigger on Caterpillar models G379, G398 and G399. Requires housing (Caterpillar P/N 2N7425) if engine has right angle service meter drive.
- 5 - Alternate ring gear has 249 teeth; check number of teeth to verify correct memory code no.



**ALTRONIC CPU-90  
MEDIUM ENGINES, 2-18 CYLINDERS**

**IDENTIFICATION  
FORM CPU-90 AL 6-93**

**HARNESSES**

<b>PART NO.</b>	<b>CONNECTOR / PINS</b>	<b>CYLS. / L1* / L2*</b>	<b>APPLICATION</b>	<b>NOTES</b>
793 012-8	180° / 19	8 / 180" / -	unshielded	
793 012-12	180° / 19	12 / 180" / -	unshielded	
793 012-16	180° / 19	16 / 180" / -	unshielded	
793 015-8	180° / 19	8 / 180" / 48"	shielded	a
793 015-12	180° / 19	12 / 180" / 48"	shielded	a
793 015-16	180° / 19	16 / 180" / 48"	shielded	a
793 022-8	180° / 19	8 / 180" / 84"	shielded	a
793 022-12	180° / 19	12 / 180" / 84"	shielded	a
793 022-16	180° / 19	16 / 180" / 84"	shielded	a
793 023-8	90° / 19	8 / 180" / 48"	shielded	a
793 023-9	90° / 19	9 / 180" / 48"	shielded	a
793 023-12	90° / 19	12 / 180" / 48"	shielded	a
793 023-16	90° / 19	16 / 180" / 48"	shielded	a
793 023-18	90° / 19	18 / 180" / 48"	shielded	a
793 024-8	90° / 19	8 / 180" / 84"	shielded	a
793 024-12	90° / 19	12 / 180" / 84"	shielded	a
793 024-16	90° / 19	16 / 180" / 84"	shielded	a

**NOTES:**

a) CSA Certified for Class I, Group D, Division 2 hazardous locations when used with applicable CSA Certified Altronic ignition unit and coils.

\* L1 = length of 16 ga. conductor  
L2 = length of conduit on shielded harnesses