

ALTRONIC®, INC.
712 TRUMBULL AVENUE
GIRARD, OHIO 44420

DIGITAL ANNUNCIATOR DD-20NT, DD-40NT

INSTALLATION INSTRUCTIONS DD-NT II 9-89

WARNING: READ THESE INSTRUCTIONS CAREFULLY BEFORE INSTALLING OR OPERATING THE DD ANNUNCIATOR SYSTEM. AN IMPROPERLY INSTALLED OR OPERATING DEVICE MAY RESULT IN AN UNSAFE OPERATING CONDITION OF THE MONITORED MACHINE WHICH CONSEQUENTLY COULD POSE THE THREAT OF PERSONAL INJURY TO OPERATORS OR OTHER NEARBY PERSONNEL.

1.0 DESCRIPTION

- 1.1 The Altronic DD digital annunciator is an electronic, 20 or 40-point monitor and shutdown device. Power requirement is extremely low allowing operation from capacitor discharge ignition systems or 12-24 VDC with approximately 1.0 watt draw.
- 1.2 The DD annunciator system is suitable for use in either Class I, Group D, Division 1 or Class I, Group D, Division 2 hazardous locations depending on the type Power Supply used. The system consists of these components:
 1. Annunciator Unit - DD-NT series
 2. Power Supply - 690 xxx-x series (Division 1)
691 xxx-x series (Division 2 or general purpose)
 3. Cable Assembly - 693 xxx-x series (required only with 690 xxx-x Power Supply)
- 1.3 For reliable operation, the following instructions must be adhered to strictly.

2.0 MOUNTING

- 2.1 ANNUNCIATOR UNIT - Using four #10 screws, mount the Annunciator Unit inside a control panel or to a suitable flat surface so that the display is at a convenient viewing height. A drilling template is provided. Be sure the panel door enclosure does not hit the timer knob. The annunciator unit box must be grounded.

NOTE: Avoid mounting with the LCD display facing direct sunlight. The display temperature range is -40°F. to +175°F.
- 2.2 690 xxx-x POWER SUPPLY - Mount the 690 series Power Supply using the two 1/4"-20 tapped holes in the bottom of the box. DO NOT drill these holes any deeper into the box. The 690 box has no gasket seal; therefore, it should be protected from direct exposure to weather.
- 2.3 691 xxx-x POWER SUPPLY - The 691 series Power Supply mounts directly to the back of the Annunciator Unit using two 8-32 x 5/16" length screws provided.

3.0 WIRING (SEE WIRING DIAGRAMS)

3.1 The Cable Assembly from the Power Supply plugs into the 5-pin connector on the back of the Annunciator Unit.

3.2 The sensor leads connect to the removable terminal strip(s) on the back of the annunciator. The terminal numbers correspond to the display numbers as follows:

<u>DD-20NT</u>	<u>DD-40NT</u>	<u>FUNCTION</u>
10-17	10-17 20-27	Class B points - monitored points disarmed by the start-up timer.
20-27 30-32 40	30-37 40-47 50-57	Class A points - monitored points not disarmed by the start-up timer.
E	E	Common for normally closed sensors.

3.3 At the terminal strip of the Annunciator unit, strip the insulation back 3/8"; twist the exposed wires tightly together. Insert the exposed wire end completely into the terminal strip and securely tighten the clamping screw. It is suggested that wire 18 AWG (max.) to 24 AWG (min.) be used for the connections directly to the annunciator terminal strip connector.

3.4 Wires running to the various sensors should be in good condition or replaced with new wiring. Terminations to the main panel terminal strip (if used) should be made with a suitable terminal and crimping tool or by soldering. There is no requirement for explosion-proof conduit or Class I enclosures; however, suitable physical protection should be provided.

CAUTION:

- a.) TO MEET THE REQUIREMENTS OF INTRINSIC SAFETY (see NFPA Standard No. 493): Sensor wires within the panel enclosure must be kept at least two (2) inches from other wiring. Use a separate junction box for ignition and fuel valve wires. Run sensor leads leaving the panel in a conduit separate from all other wiring and keep separate throughout the installation. Wiring to the sensors must have a grade of insulation capable of withstanding an AC voltage of 500 V. rms. Sensor leads may be connected to any passive device using contacts such as standard switch gauges or level switches. DO NOT connect sensor leads to relay contacts or to any voltage producing element.
 - b.) Sensors will be exposed to much lower voltages and current than with the standard Murphy or similar type system. In the case of a field conversion where sensors have previously been used with Murphy tattletales, it is recommended that the sensors be checked frequently (see Test procedure under OPERATION, section 4.0) when the DD system is first put into use. Sensor contacts may be burned or pitted from past exposure to ignition system primary voltage. It is advisable to replace such sensors.
 - c.) If it becomes necessary to check sensor to panel wiring with an ohmmeter or other checker, first DISCONNECT the plug-in terminal strips from the back of the Annunciator Unit. Applying voltage to the annunciator through the sensor leads may damage the device. In addition, the area should be tested as non-hazardous before such testing commences.
- 3.5 Where the 690 series Power Supply is used, wiring from the power source enters through the entry at one end of the box. The conduit hook-up to the box must conform with applicable Electrical Code for the particular area classification. See the attached Wiring Diagrams for details of each particular Power Supply.

4.0 OPERATION

4.1 OPERATING SEQUENCE

<u>DISPLAY</u>	<u>EQUIPMENT</u>	<u>FUNCTION</u>	<u>DESCRIPTION</u>
[10-57]	Down	Shutdown	Equipment shutdown caused by the number indicated. Number will remain until the fault is corrected and RESET button depressed.
[00]	Down	Reset	Before starting equipment, momentarily push the RESET button. A display of [00] indicates all Class A sensors (see section 3.2) are ready for start-up. Any number 10-57 indicates a faulted sensor that must be cleared before start-up.
[80]	Down	Battery Test	TEST button held depressed - indicates satisfactory battery voltage.
[60]	Down	Engine Purge	To purge engine without engine firing, depress the STOP button, roll the engine to purge, then push RESET button. Engine can then be started provided display reads [00].
[00]	Running	Start-up	Start-up timer has Class B points (see section 3.2) disarmed. All Class A points are being monitored. Pushing the RESET button re-cycles the start-up timer. To cancel the start-up timer, turn the Timer Switch to the "0" position.
[01]	Running	Normal Operation	All points are being monitored. The transition from [00] to [01] indicates the end of the start-up timer interval.
[89]	Running	Voltage Test	TEST button held depressed - indicates satisfactory operating voltage.
[09]	Running	Sensor Test	TEST button released - a timed test period initiated for approximately two minutes. As a sensor is faulted, its number is latched on the display (but the output signal is not activated). To move to the next point, first clear the sensor, then push the TEST button again. The display reverts to [09] until the next sensor is faulted. After the last test, push the TEST button to get [09] on the display; wait two minutes until [01] displays.
[01]	Running	Normal Operation	Test period has ended; all points are being monitored. DO NOT LEAVE ENGINE UNLESS DISPLAY READS [01].

CAUTION: DO NOT DEPEND ON FAULTING A SENSOR PRIOR TO ROLLING THE ENGINE TO PREVENT IGNITION. THE PROPER PROCEDURE IS GIVEN ABOVE UNDER "Engine Purge". AN ENGINE THAT ATTEMPTS TO START UNEXPECTEDLY CAN POSE A RISK OF PERSONAL INJURY.

NOTE:

- a.) TEST cannot be used until the start-up timer interval ends - [01] on the display.
- b.) A display reading of [09] means the system output will not activate unless the STOP button is pushed.
- c.) Do not leave a sensor number on the display after the last test; push the TEST button to get [09] on the display; then wait two minutes until [01] displays.
- d.) For a complete system test, allow the test timer interval to expire - display changes from [09] to [01]. Then cause one sensor to fault and allow the system output to activate. This will test the entire DD system for correct operation upon a fault with minimal downtime.

4.2 START-UP TIMER - The timer switch is located at the lower right corner on the front of the Annunciator Unit. The switch may be set from 0 to 9 minutes as indicated on the label. The timer cycle begins as soon as the annunciator is powered. To re-cycle the timer, momentarily push the RESET button. To manually end the timer lock-out period, turn the timer switch to the "0" position; once [01] appears, the timer switch can then be reset to any desired time for the next start-up.

4.3 STOP BUTTON - Depressing the STOP button initiates the output sequence regardless of the annunciator operating mode. The display will read [60] whenever the STOP button is depressed. The STOP button may also be used to purge the engine before start-up - see fourth item in section 4.1, OPERATING SEQUENCE.

4.4 BATTERY - The 690 101-3, 690 110 and 690 112 series Power Supplies contain special lithium long-life batteries. When the monitored equipment is not operating, current draw from the battery is only 15 microamp (.000015 amp). When the annunciator is powered, there is no drain from the battery.

NOTE: If the equipment is to remain out of service for a prolonged period of time, disconnect the 5-pin connector from the back of the Annunciator Unit.

- A. The two batteries in the 690 101-3 power supply are replaceable; use ONLY Altronic 601 248, Sanyo 2CR-1/3N or Duracell PX28L. Be sure to observe the proper polarity when replacing the batteries.
- B. The battery in the 690 110 and 690 112 is not replaceable and should not be removed. These should be returned to an authorized Altronic outlet for servicing if the battery needs replacement.

GENERAL HOOK-UP - NORMALLY OPEN SENSORS

CLASS I, GROUP D, DIVISION 1 APPLICATIONS

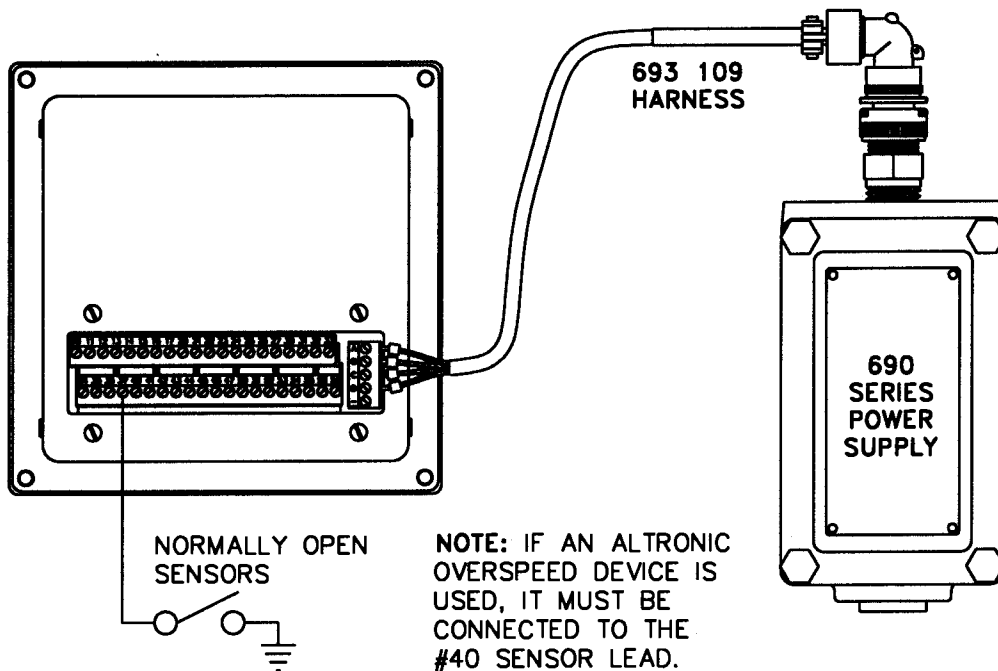

CLASS I, GROUP D, DIVISION 2 APPLICATIONS

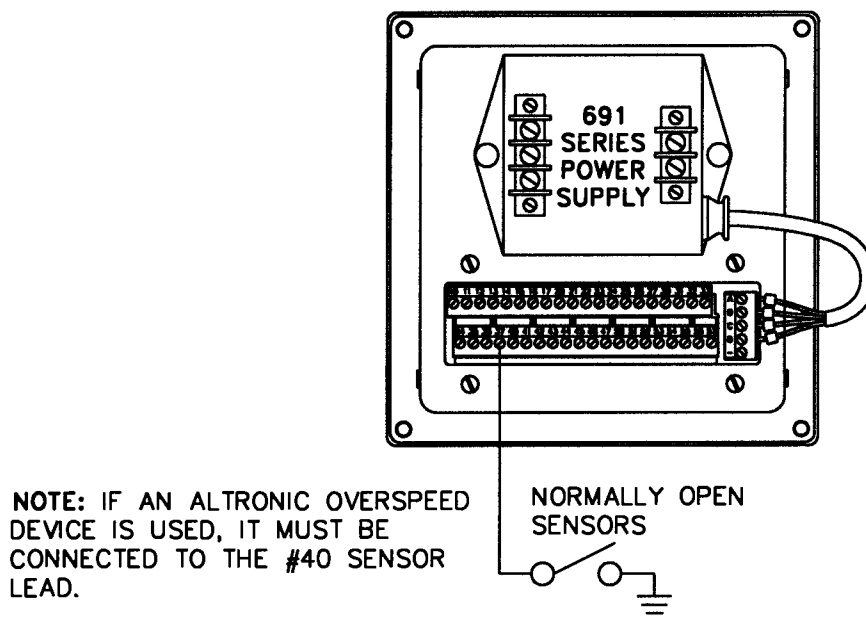

WARNING: SENSOR LEADS FROM THE ANNUNCIATOR MUST NOT CONTACT ANY EXTERNAL VOLTAGE SOURCE. DAMAGE TO THE SYSTEM WILL RESULT FROM CONNECTION BETWEEN THE SENSOR LEADS AND THE IGNITION SYSTEM OR ANY AC OR DC POWER SOURCE.

GENERAL HOOK-UP - NORMALLY CLOSED SENSORS

CLASS I, GROUP D, DIVISION 1 APPLICATIONS

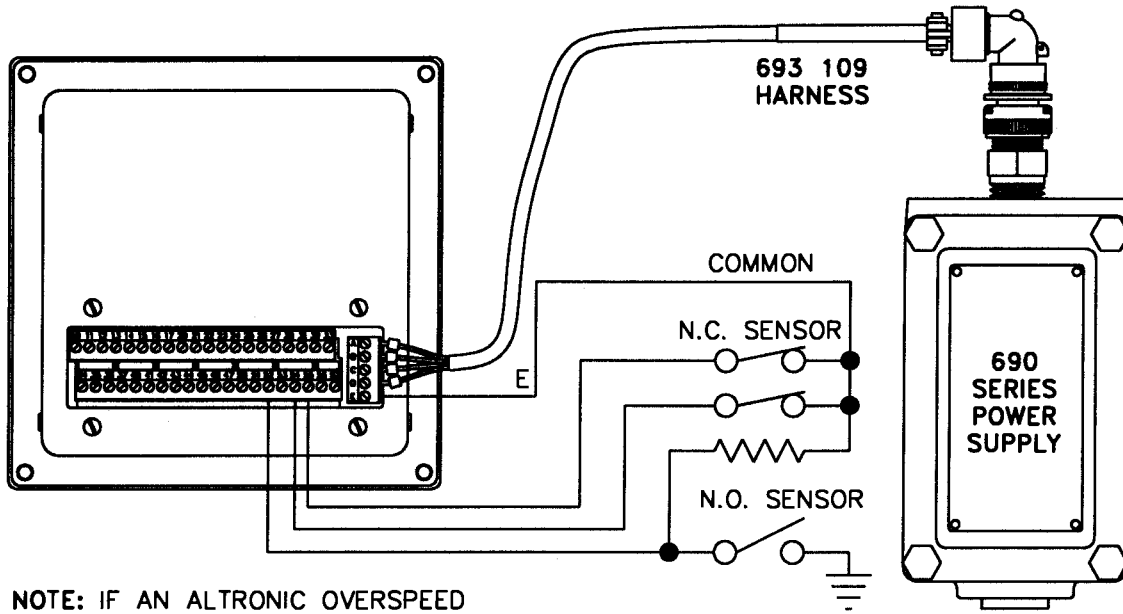

NOTE: IF AN ALTRONIC OVERSPEED DEVICE IS USED, IT MUST BE CONNECTED TO THE #40 SENSOR LEAD.

ADD 18K Ω , 1/2W RESISTOR AS SHOWN FOR EACH NORMALLY OPEN SENSOR USED WITH A NORMALLY CLOSED ANNUNCIATOR.

CLASS I, GROUP D, DIVISION 2 APPLICATIONS

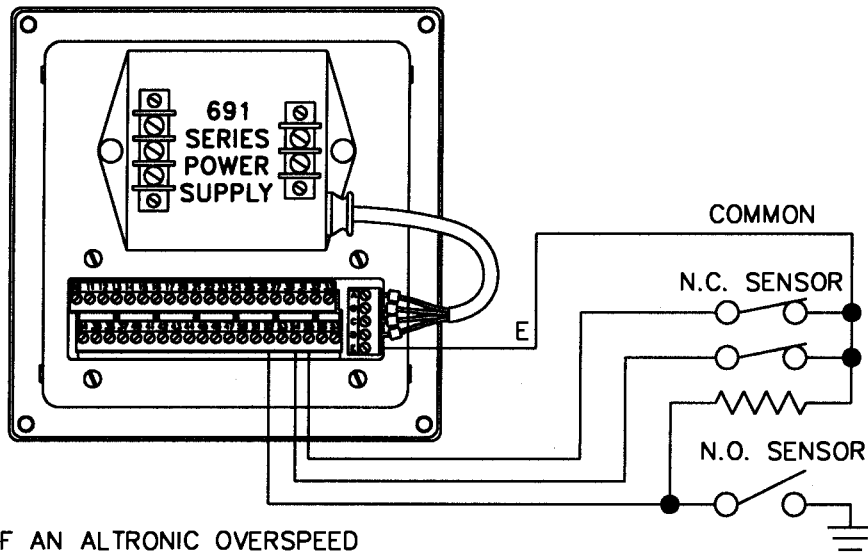

NOTE: IF AN ALTRONIC OVERSPEED DEVICE IS USED, IT MUST BE CONNECTED TO THE #40 SENSOR LEAD.

ADD 18K Ω , 1/2W RESISTOR AS SHOWN FOR EACH NORMALLY OPEN SENSOR USED WITH A NORMALLY CLOSED ANNUNCIATOR.

WARNING: SENSOR LEADS FROM THE ANNUNCIATOR MUST NOT CONTACT ANY EXTERNAL VOLTAGE SOURCE. DAMAGE TO THE SYSTEM WILL RESULT FROM CONNECTION BETWEEN THE SENSOR LEADS AND THE IGNITION SYSTEM OR ANY AC OR DC POWER SOURCE.

WIRING DIAGRAM

691 150-1 POWER SUPPLY 100-350VDC
NEGATIVE GROUND C.D. IGNITION ONLY

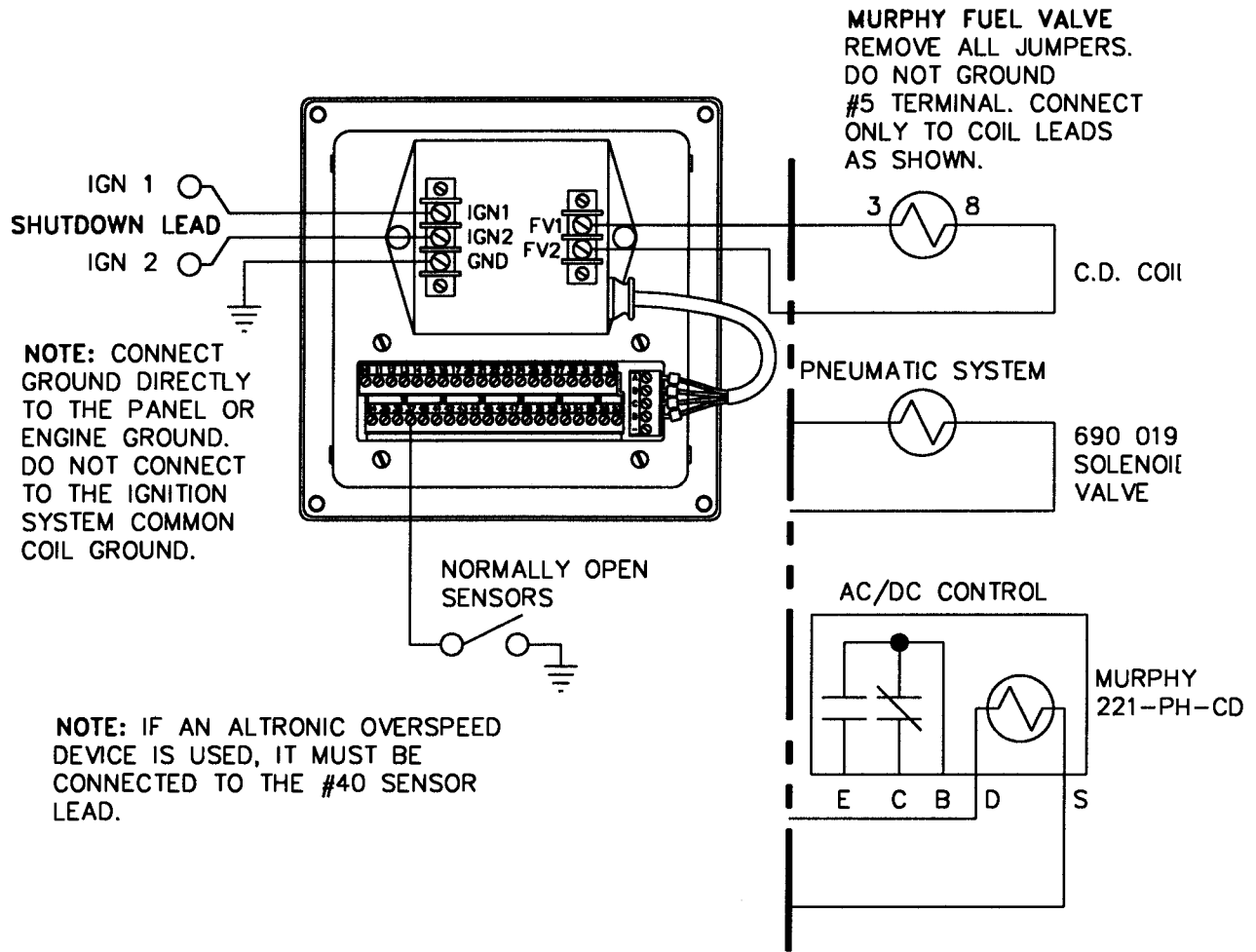

WARNING: SENSOR LEADS FROM THE ANNUNCIATOR MUST NOT CONTACT ANY EXTERNAL VOLTAGE SOURCE. DAMAGE TO THE SYSTEM WILL RESULT FROM CONNECTION BETWEEN THE SENSOR LEADS AND THE IGNITION SYSTEM OR ANY AC OR DC POWER SOURCE.

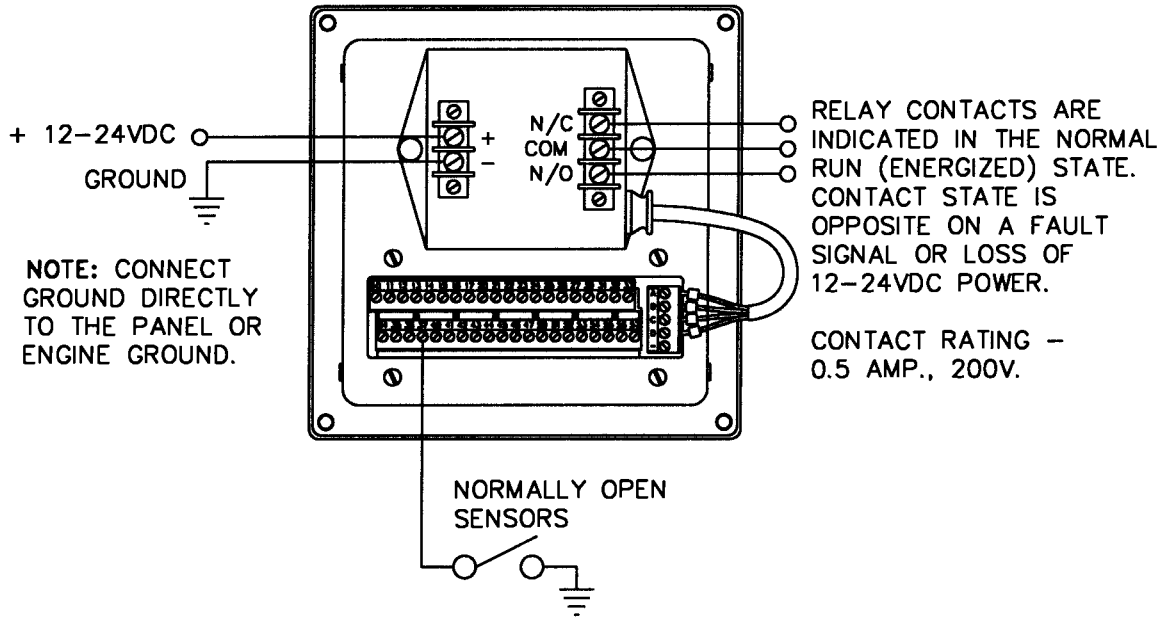

NOTE: IF AN ALTRONIC OVERSPEED DEVICE IS USED, IT MUST BE CONNECTED TO THE #40 SENSOR LEAD.

WARNING: SENSOR LEADS FROM THE ANNUNCIATOR MUST NOT CONTACT ANY EXTERNAL VOLTAGE SOURCE. DAMAGE TO THE SYSTEM WILL RESULT FROM CONNECTION BETWEEN THE SENSOR LEADS AND THE IGNITION SYSTEM OR ANY AC OR DC POWER SOURCE.

WIRING DIAGRAM

690 101-3 POWER SUPPLY 100-350V
NEGATIVE GROUND C.D. IGNITION ONLY

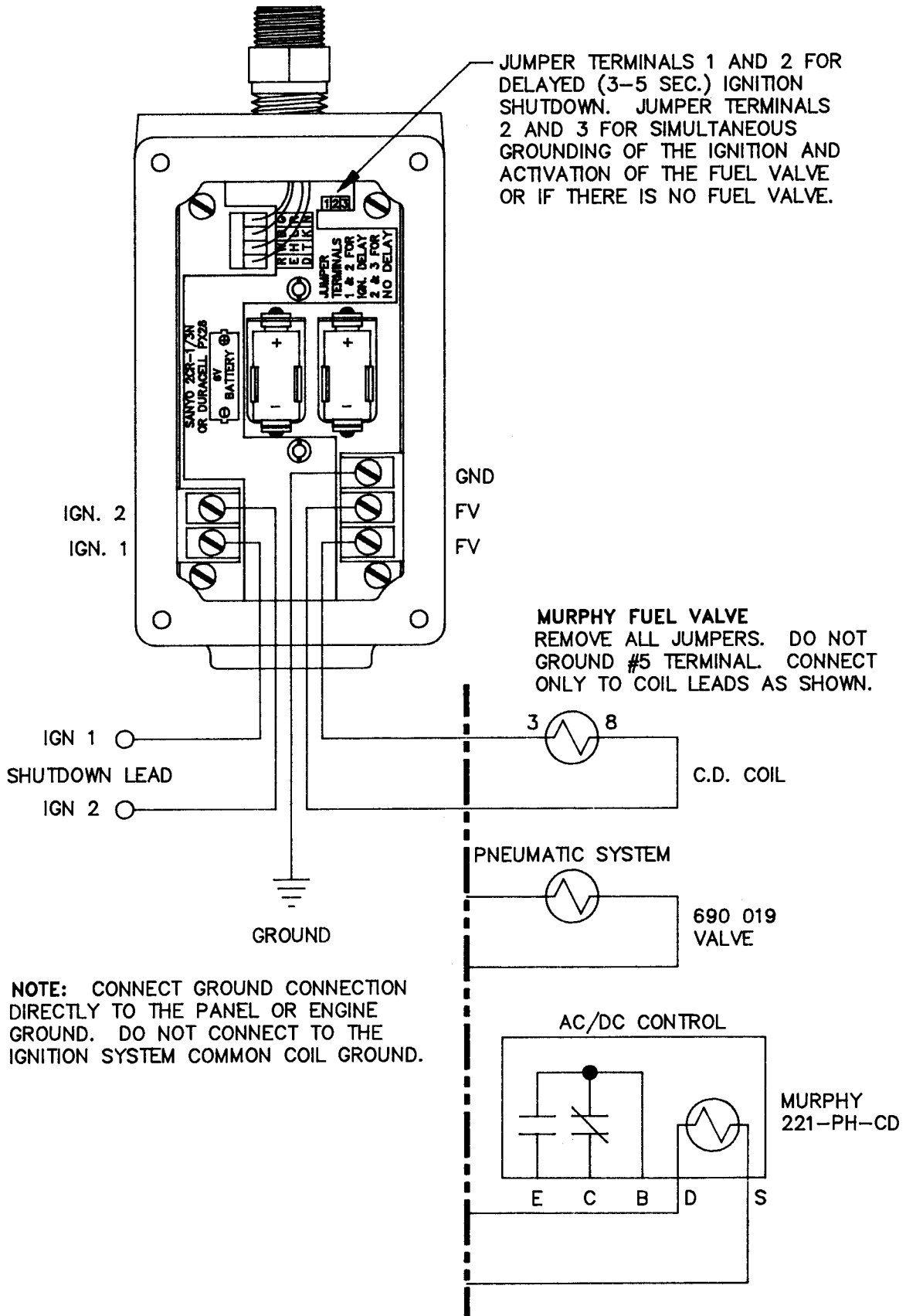

NOTE: CONNECT GROUND CONNECTION DIRECTLY TO THE PANEL OR ENGINE GROUND. DO NOT CONNECT TO THE IGNITION SYSTEM COMMON COIL GROUND.

WIRING DIAGRAM

690 105 POWER SUPPLY 12-24 VDC

GENERAL HOOK-UP

CUT AND REMOVE JUMPER FOR 3-5 SECOND DELAY ON RELAY #2.

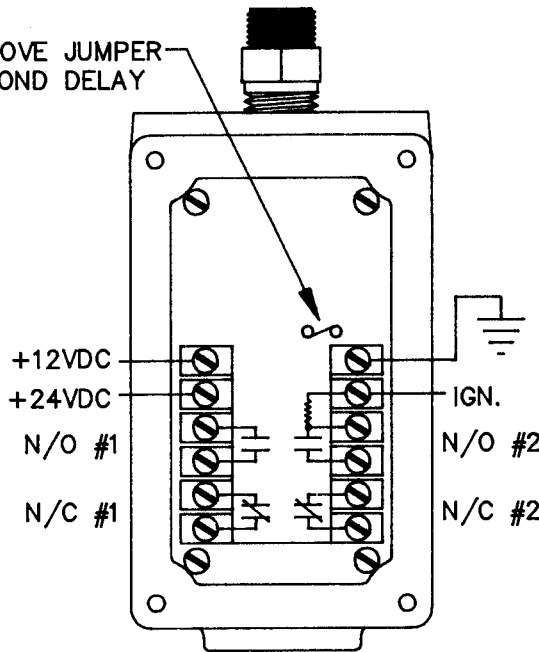

RELAY CONTACTS ARE SHOWN IN THE NORMAL RUN CONDITION. CONTACT STATE IS OPPOSITE ON FAULT SIGNAL OR ON LOSS OF 12-24 VDC POWER. FAULT SIGNAL CAUSES RELAY #1 TO CHANGE STATE IMMEDIATELY. RELAY #2 SWITCHES SIMULTANEOUSLY (JUMPER LEFT IN PLACE) OR WITH A 3-5 SEC. DELAY (JUMPER CUT AND REMOVED).

IGNITION SHUTDOWN AND 12-24VDC FUEL VALVE SOLENOID HELD ENERGIZED FOR NORMAL RUN.

NOTE: 12-24VDC POWER MUST BE MAINTAINED TO RETAIN SHUTDOWN FAULT NUMBER. FOR REMOTE CONTROLLED RESET, THE DC POWER MAY BE REMOVED FOR 5 SECONDS AND THEN RE-APPLIED; THIS WILL RESET THE START-UP TIMER.

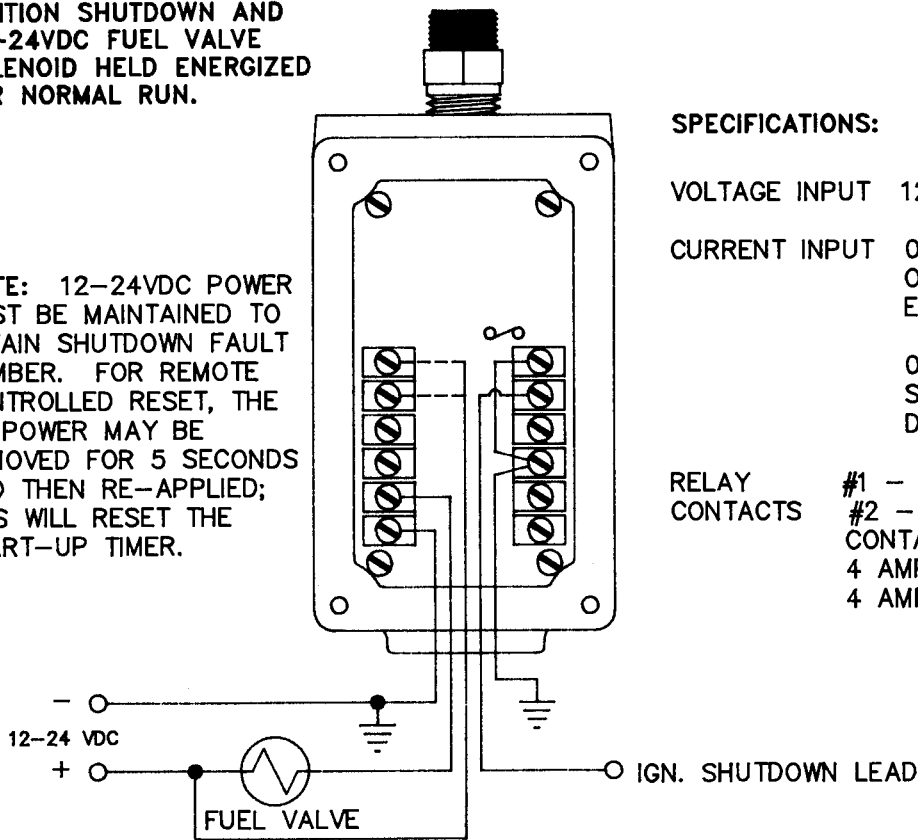

SPECIFICATIONS:

VOLTAGE INPUT 12VDC OR 24VDC

CURRENT INPUT 0.040 AMP - NORMAL OPERATION (RELAYS ENERGIZED)

0.002 AMP - AFTER SHUTDOWN (RELAYS DE-ENERGIZED)

RELAY CONTACTS #1 - 1 N/O AND 1 N/C
#2 - 1 N/O AND 1 N/C
CONTACT RATING -
4 AMP, 24VDC;
4 AMP, 220VAC

WIRING DIAGRAM

**690 110 POWER SUPPLY 150-350V
POSITIVE GROUND C.D. IGNITION ONLY**

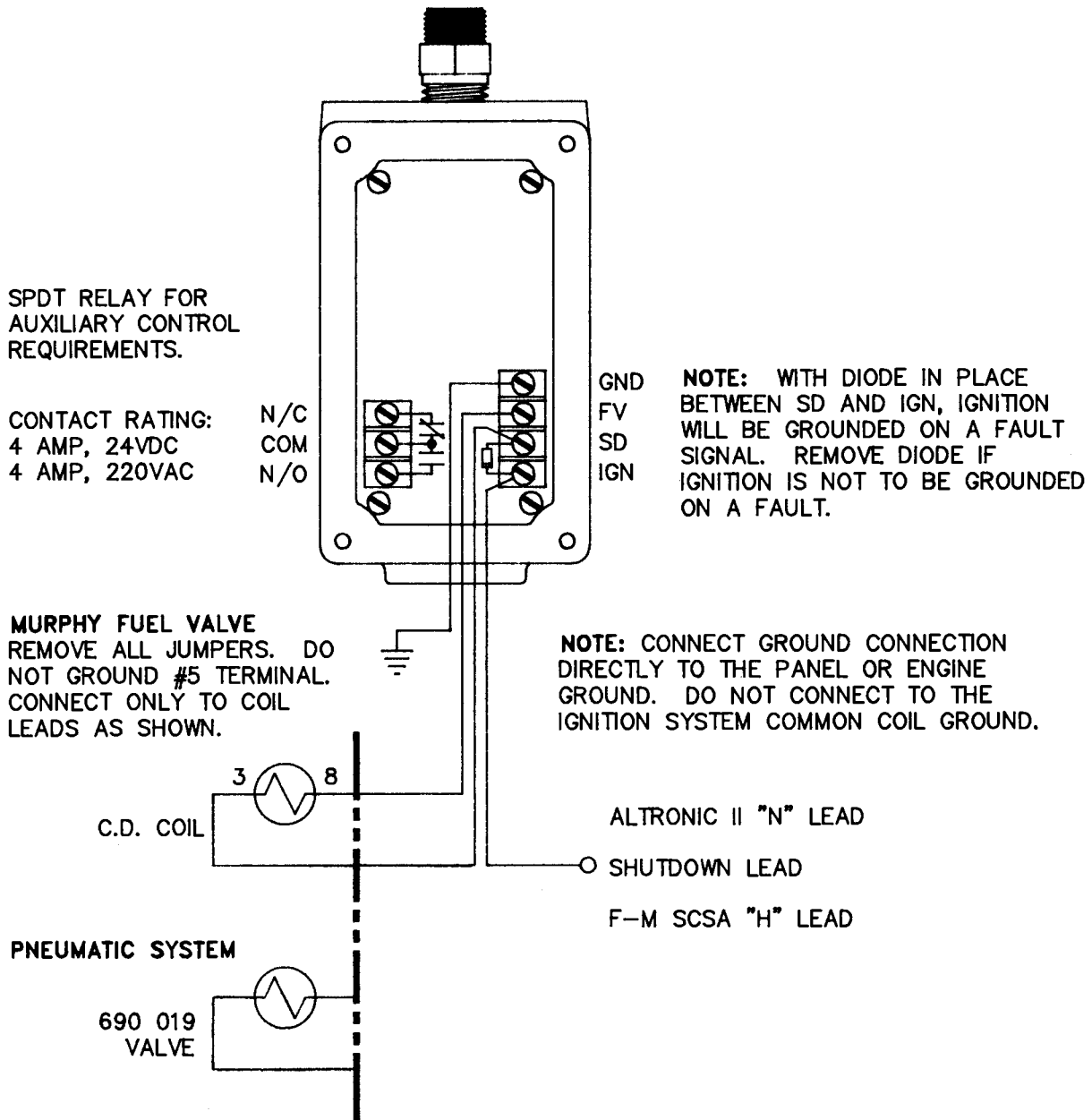

INITIAL START-UP: AFTER INSTALLING AN ANNUNCIATOR SYSTEM USING THE 691 110 POWER SUPPLY OR AFTER TROUBLESHOOTING PROCEDURE WHEN COMPONENTS HAVE BEEN CHANGED, PRESS THE STOP BUTTON ON THE ANNUNCIATOR LOGIC UNIT TO INITIALIZE THE LATCHING RELAY IN THE POWER SUPPLY. ONCE THE RELAY AND LOGIC UNIT ARE SYNCHRONIZED, THE SYSTEM CAN BE RESET FOR START-UP BY PUSHING THE RESET BUTTON. FAILURE TO PRESS THE STOP BUTTON WILL LEAVE THE SYSTEM LATCHED IN THE STOP MODE REGARDLESS OF HOW MANY TIMES THE RESET BUTTON IS PUSHED.

WIRING DIAGRAM
 CLASS I, GROUP D, DIVISION 2 APPLICATIONS

691 155-1
 12-24 VDC POWER SUPPLY
 WITH BATTERY BACK-UP

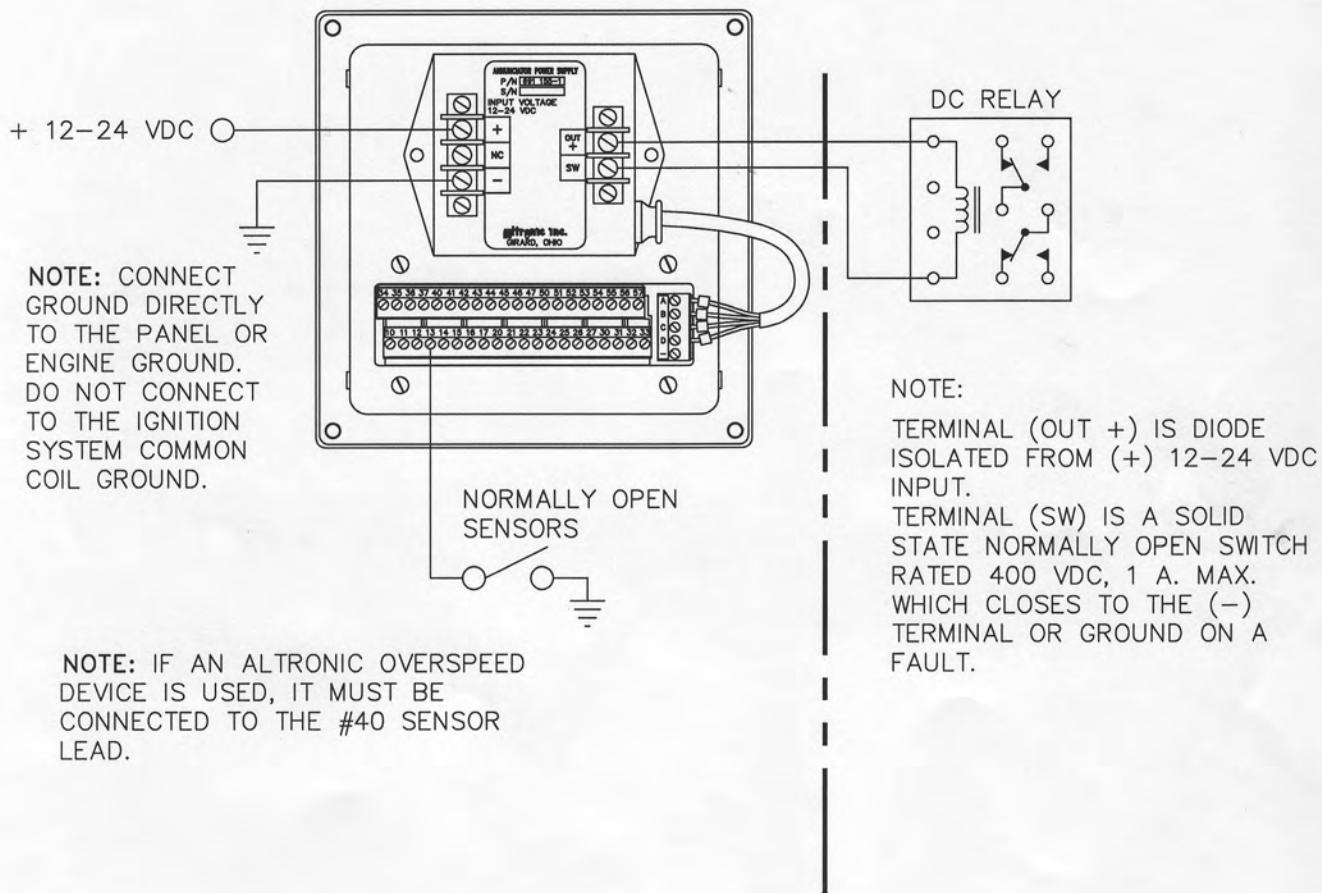

NOTE: CONNECT GROUND DIRECTLY TO THE PANEL OR ENGINE GROUND. DO NOT CONNECT TO THE IGNITION SYSTEM COMMON COIL GROUND.

NOTE: IF AN ALTRONIC OVERSPEED DEVICE IS USED, IT MUST BE CONNECTED TO THE #40 SENSOR LEAD.

NOTE:
 TERMINAL (OUT +) IS DIODE ISOLATED FROM (+) 12-24 VDC INPUT.
 TERMINAL (SW) IS A SOLID STATE NORMALLY OPEN SWITCH RATED 400 VDC, 1 A. MAX. WHICH CLOSSES TO THE (-) TERMINAL OR GROUND ON A FAULT.

WARNING: SENSOR LEADS FROM THE ANNUNCIATOR MUST NOT CONTACT ANY EXTERNAL VOLTAGE SOURCE. DAMAGE TO THE SYSTEM WILL RESULT FROM CONNECTION BETWEEN THE SENSOR LEADS AND THE IGNITION SYSTEM OR ANY AC OR DC POWER SOURCE.

12

WIRING DIAGRAM

**690 112 POWER SUPPLY 150-350V
NEGATIVE GROUND C.D. IGNITION ONLY**

NOTE: THE 690 112 POWER SUPPLY CANNOT BE USED WITH ALTRONIC I OR ALTRONIC V IGNITION SYSTEMS.

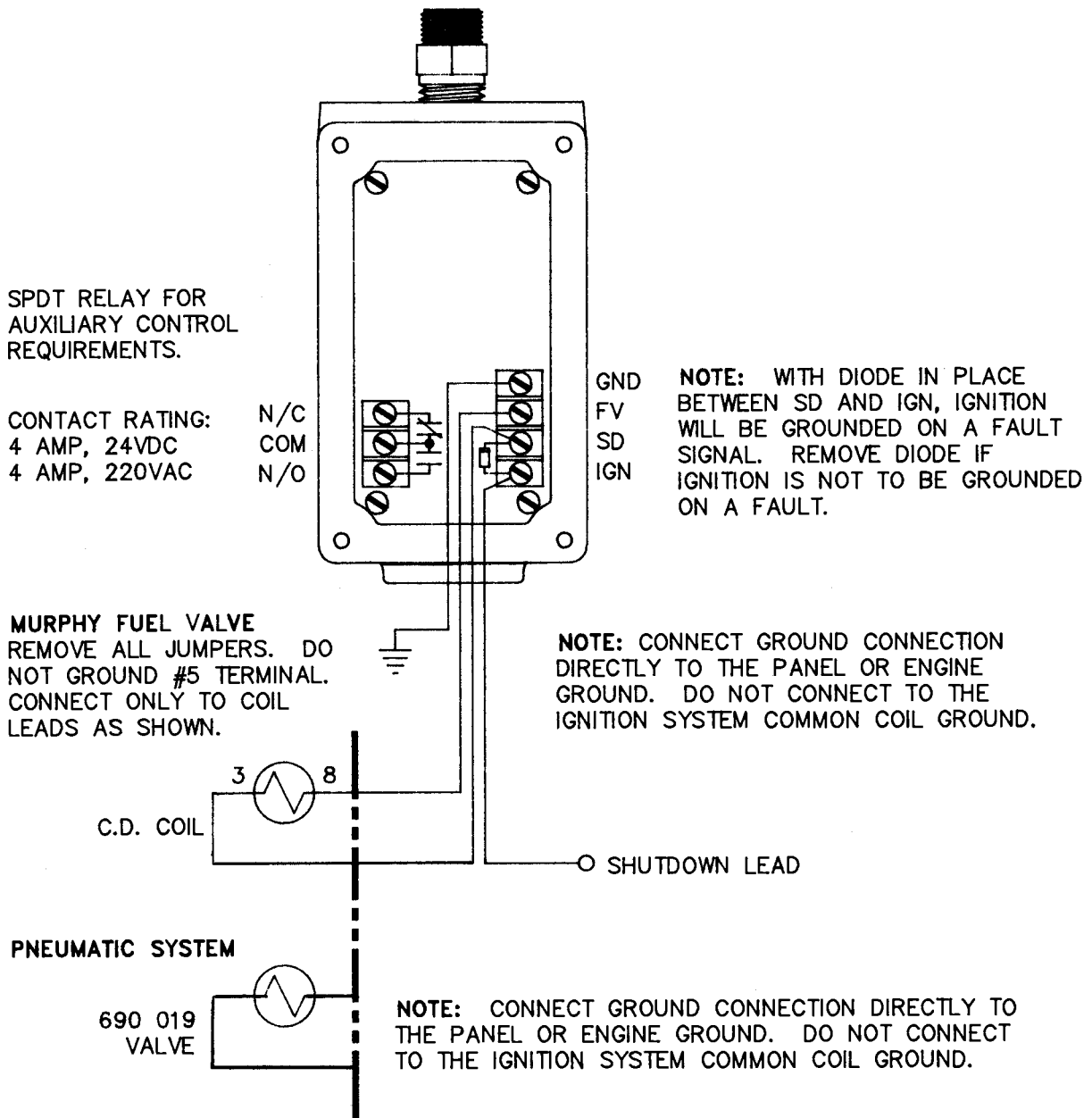

INITIAL START-UP: AFTER INSTALLING AN ANNUNCIATOR SYSTEM USING THE 690 112 POWER SUPPLY OR AFTER TROUBLESHOOTING PROCEDURE WHEN COMPONENTS HAVE BEEN CHANGED, PRESS THE STOP BUTTON ON THE ANNUNCIATOR LOGIC UNIT TO INITIALIZE THE LATCHING RELAY IN THE POWER SUPPLY. ONCE THE RELAY AND LOGIC UNIT ARE SYNCHRONIZED, THE SYSTEM CAN BE RESET FOR START-UP BY PUSHING THE RESET BUTTON. FAILURE TO PRESS THE STOP BUTTON WILL LEAVE THE SYSTEM LATCHED IN THE STOP MODE REGARDLESS OF HOW MANY TIMES THE RESET BUTTON IS PUSHED.

WIRING DIAGRAM
CLASS I, GROUP D, DIVISION 2 APPLICATIONS

691 180-1 9-96
12-24 VDC IGNITION SYSTEMS
DD ANNUNCIATOR POWER SUPPLY
WITH BATTERY BACK-UP

TO PLUS TERM.
OF 12-24 VDC
IGNITION SYSTEM

GROUND

+ 12-24 VDC
FROM POWER
SUPPLY

NOTE: CONNECT
GROUND DIRECTLY
TO THE PANEL OR
ENGINE GROUND.
DO NOT CONNECT
TO THE IGNITION
SYSTEM COMMON
COIL GROUND.

REMOVE CAP TO ADJUST
VARIABLE TRIP DELAY
FOR IGNITION SWITCH
(TERMINAL 3) AND
AUXILIARY SWITCH 2
(TERMINALS 7, 8 AND 9).

APPROXIMATE TRIP DELAY
TIME FOR TRIMPOT POSITIONS

POSITION	TIME (SEC.)
0	0
1	1
2	4
3	7
4	10
5	14
6	18
7	22
8	25
9	28
10	30

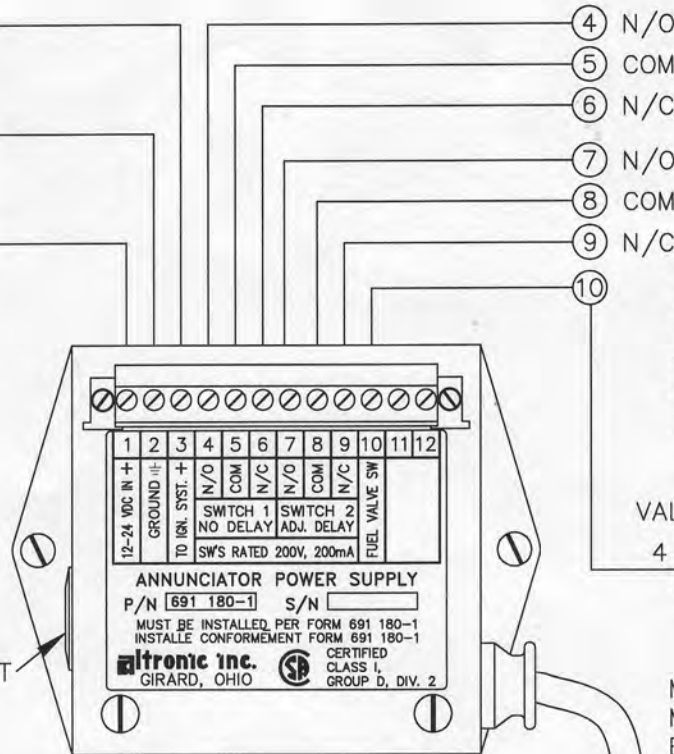

4 N/O AUX. SWITCH 1
5 COM NO DELAY
6 N/C 200V / 200 MA

7 N/O AUX. SWITCH 2
8 COM VARIABLE DELAY
9 N/C 200V / 200 MA

RELAY CONTACTS ARE
SHOWN IN THE NORMAL
RUN CONDITION. CONTACT
STATE IS OPPOSITE ON
FAULT SIGNAL OR ON
LOSS OF 12-24 VDC.

VALVE COIL

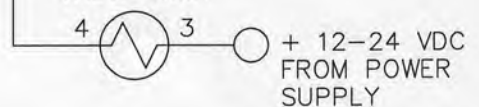

MURPHY FUEL VALVE
MODEL M5081
ENERGIZED TO CLOSE

FUEL VALVE SWITCH
(TERM. 10) IS OPEN
TO GROUND FOR
NORMAL RUN CONDITION
AND CLOSSES WITHOUT
DELAY UPON A FAULT.
RATING IS 32 VDC,
5 AMPS MAX.

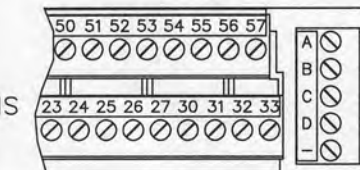

IGNITION SWITCH (TERMINAL 3) - CLOSED FOR RUN,
ADJUSTABLE TRIP TIME. RATED 32 VDC, 5 AMPS MAX.
FUSED WITH A 6.3 AMP SLOW BLOW FUSE IN 691 180-1 P.S.
REPLACEMENT FUSE ALTRONIC P/N 601 653

FUEL VALVE SWITCH (TERMINAL 10) - OPEN FOR RUN,
IMMEDIATE TRIP. RATED 32 VDC, 5 AMPS MAX.

AUX. SWITCH 1 (TERMINALS 4, 5 AND 6) - TERM. 4 AND 5 OPEN
FOR RUN, TERM. 5 AND 6 CLOSED FOR RUN. IMMEDIATE TRIP.
RATED 200 V, 200 MA ISOLATED SOLID STATE AC/DC RELAY.

AUX. SWITCH 2 (TERMINALS 7, 8 AND 9) - TERM. 7 AND 8 OPEN FOR
RUN, TERM. 8 AND 9 CLOSED FOR RUN. ADJUSTABLE TRIP TIME.
RATED 200 V, 200 MA ISOLATED SOLID STATE AC/DC RELAY.

WARNING: SENSOR LEADS FROM THE ANNUNCIATOR MUST NOT CONTACT ANY EXTERNAL VOLTAGE SOURCE. DAMAGE TO THE SYSTEM WILL RESULT FROM CONNECTION BETWEEN THE SENSOR LEADS AND THE IGNITION SYSTEM OR ANY AC OR DC POWER SOURCE.