

WARNING: DEVIATION FROM THESE INSTALLATION INSTRUCTIONS MAY LEAD TO IMPROPER ENGINE OPERATION WHICH COULD CAUSE PERSONAL INJURY TO OPERATORS OR OTHER NEARBY PERSONNEL.

1.0 DESCRIPTION

- 1.1 The Altronic V self-powered ignition system consists of these basic components:
1. Altronic V unit
 2. Wiring harness
 3. Ignition coils - 501 061, 501 061-S, 591 010, 591 010-S, 591 040 (one per cylinder)

2.0 ENGINE

- 2.1 Set the engine so that no. 1 cylinder is at the desired ignition firing point.

3.0 DIRECTION OF ROTATION

- 3.1 Determine the rotation of the Altronic V unit (looking at the drive end of the Altronic V) for the engine being equipped.

4.0 ALTRONIC V UNIT

- 4.1 Locate the timing mark on the housing for the proper rotation (see drawing 509 102). Rotate the unit shaft until the red mark on the shaft lines up with the proper mark on the housing.
- 4.2 Mount the unit on the engine drive keeping the two red marks lined up as close as possible. Install and tighten finger-tight two 3/8"-16 mounting bolts. See drawing 509 101 for dimensions of the various Altronic V models.
- 4.3 Once the unit is mounted, rotate the entire unit to cause the two red timing lines to meet. If the red lines cannot be made to meet in this manner, remove the four screws which fasten the back cover assembly to the unit. The entire back cover assembly should then be pulled away from the unit keeping the internal plug connected. Rotate the distributor gear until the two marks described above line up. Then reinstall the back cover to the unit, engaging the gears, and keeping the two red marks together. If necessary, the plastic cover can be removed to keep one finger on the timing decal to maintain the proper alignment of the two red timing marks. Securely tighten the four cover mounting screws.

- 4.4 Final timing should be set using a timing light with the engine at operating speed. The entire unit is rotated to adjust ignition timing.
- 4.5 Tighten the two 3/8"-16 mounting bolts.

5.0 IGNITION COILS

- 5.1 Use only the Altronic coils listed in section 1.1.
- 5.2 Mount the ignition coils as close to the spark plugs as possible keeping the high-tension lead length to a minimum but also keeping temperature below 200°F. (95°C.) during operation.

6.0 PRIMARY WIRING

6.1 The firing order of the Altronic V units is as follows:

NO. OF CYLS.	ALTRONIC V UNIT NO.	FIRING ORDER CCW ROTATION	FIRING ORDER CW ROTATION	WIRING DIAGRAM
1**	1A18	A	A	1A
1*	1A28H	A	A	1B
2**	2A14	A-B	A-B	2A
2*	2A25, 2A28	A-B	A-B	2A
2*	2A28H	A-B	A-B	2B
3**	3A14	A-C-B	A-B-C	3A
3*	3A25, 3A35	A-B-C	A-C-B	3B
4**	2A14, 2A64	A-B-A-B	A-B-A-B	4
4*	4A24, 4A34	A-B-C-D	A-D-C-B	6
5*	5A24	A-B-C-D-E	A-E-D-C-B	6
6**	3A14, 3A64	A-B-C-A-B-C	A-C-B-A-C-B	5
6*	6A24, 6A34	A-B-C-D-E-F	A-F-E-D-C-B	6

* Single firing unit - fires each cylinder individually on the compression stroke only.
 **Double firing unit - fires on exhaust stroke as well as compression stroke.

- 6.2 Starting with lead "A" to the coil of no. 1 cylinder, the harness leads are connected in accordance with the engine's firing order to the positive (+) terminals of the coils - see wiring diagrams. On exhaust stroke firing units (**), the coils for the cylinders with the same harness letter are connected in SERIES as shown in the wiring diagrams.
- 6.3 A common ground lead connecting the negative (-) terminals of the coils must be connected as shown in the wiring diagrams.
- 6.4 All connections should be made using ring type terminals specified for 16 gauge wire and #10 stud size. Terminals should either be soldered to the wire or attached with an appropriate staking tool. All primary wiring should be protected from physical damage, vibration and temperatures in excess of 200°F. (95° C.).
- 6.5 SHIELDED SYSTEM - Request Altronic drawing 509 013 for detail.

7.0 SHUTDOWN WIRING

- 7.1 The shutdown harness lead must be grounded to shut-off the ignition. The shutdown lead is identified:
- "E" for units with a 5-pin connector (models 1A, 2A, 3A);
 - "G" for units with a 7-pin connector (models 4A, 5A, 6A).
- 7.2 For proper operation of Murphy tattletale switches or fuel valve, use panel adapter 501 213 as shown in the wiring diagrams.

8.0 SECONDARY WIRING

- 8.1 The spark plug leads should be fabricated from 7 mm, silicone insulated, tinned copper conductor with suitable terminals and silicone spark plug boot. Keep spark plug leads as short as possible and in all cases not longer than 20 inches (500 mm). Spark plug leads should be kept at least 2 inches (50 mm) away from any grounded engine part. In deep spark plug wells, use rigid, insulated extenders projecting out of the well.
- 8.2 The use of a clear, silicone grease (such as Dow Corning DC-4, G.E. G-623 or GC Electronics Z5) is recommended for all high-tension connections and boots. This material helps seal out moisture and prevent corrosion from atmospheric sources.

CW ROTATION

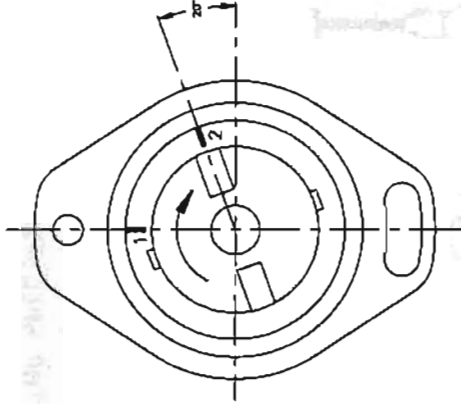

NOTE:
FOR -AM MODELS, THE COUPLING LUG
ANGLE IS 45° INSTEAD OF 20°.

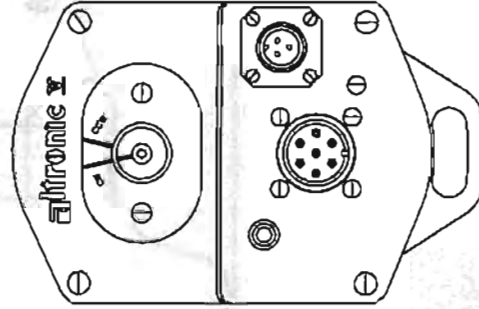

CCW ROTATION

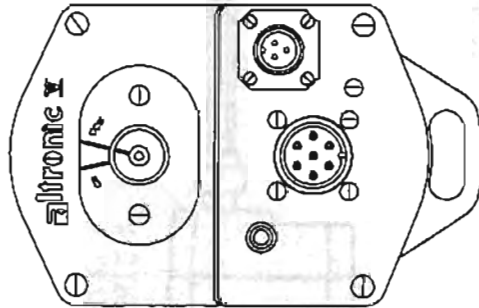
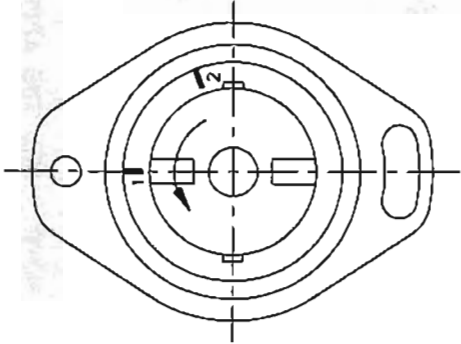

TOLERANCES UNLESS OTHERWISE SPECIFIED		REVISIONS		ALTRONIC INC.	
NO.	DATE	BY	DESCRIPTION	DATE	TITLE
1					ALTRONIC V UNIT TIMING
2					
3					
4					
5					

DESIGNED BY	WTP	SCALE	NONE	PART NUMBER	509 102
DRAWN BY					
CHECKED BY					
APPROVED BY					

TYPICAL INSTALLATION - 4-CYLINDER SHOWN

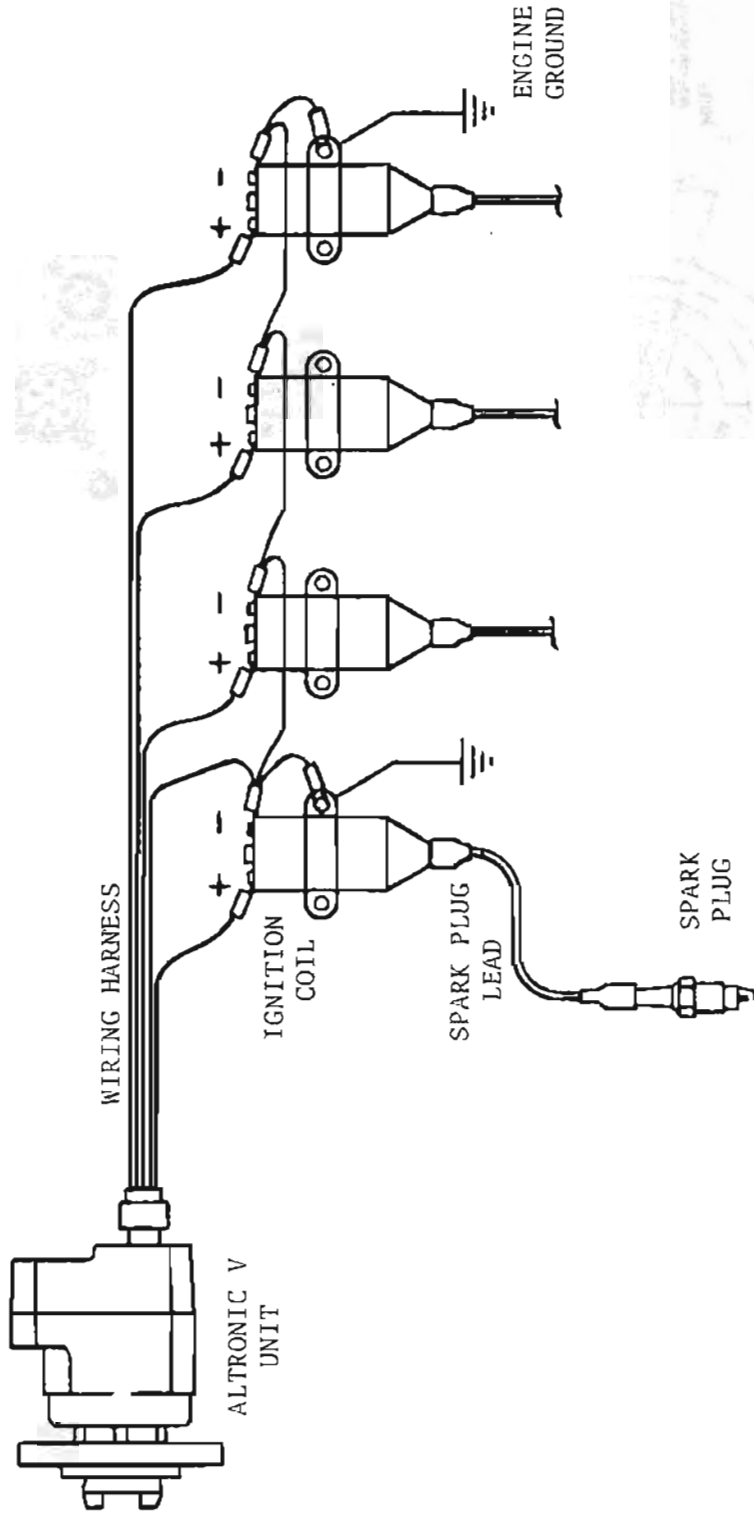

NOTE: SEE THE APPROPRIATE WIRING DIAGRAM FOR THE SPECIFIC APPLICATION.

FIG. 1A

1-CYL., 1 SPARK PLUG
UNIT 1A18

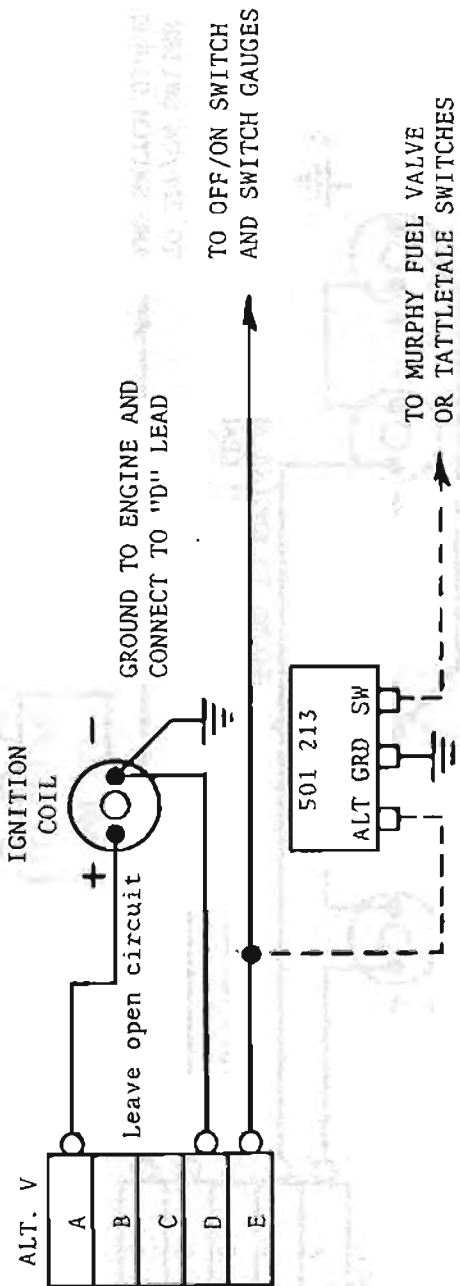

FIG. 1B

1-CYL., 2 SPARK PLUGS
UNIT 1A28H

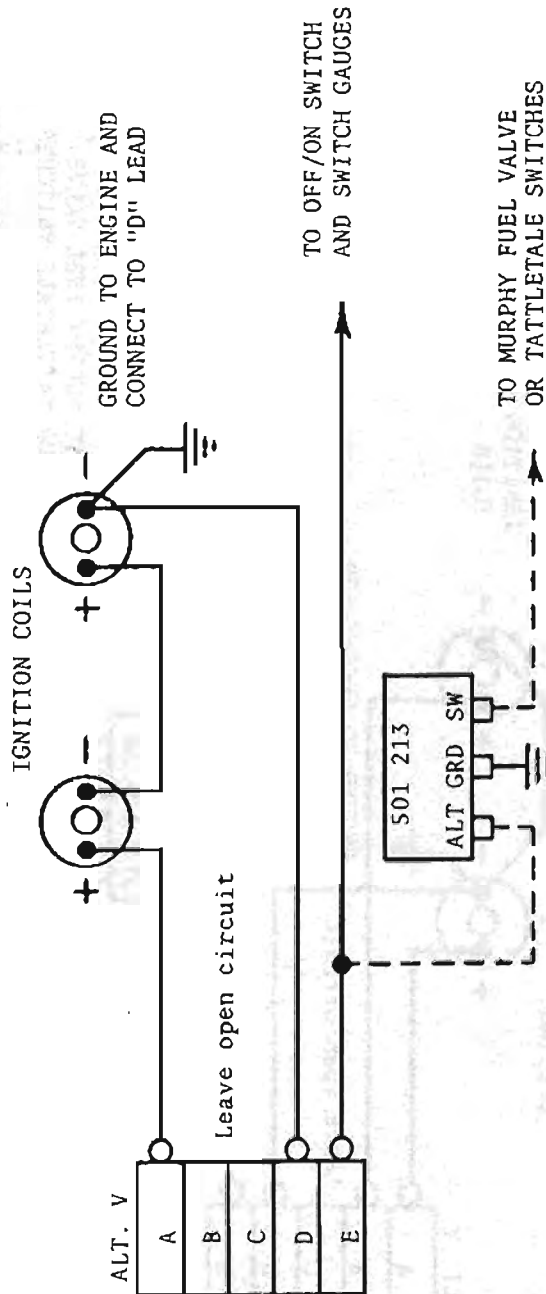

FIG. 2A

2-CYL., 1 PLUG/CYL.
UNIT 2A14, 2A25, 2A28

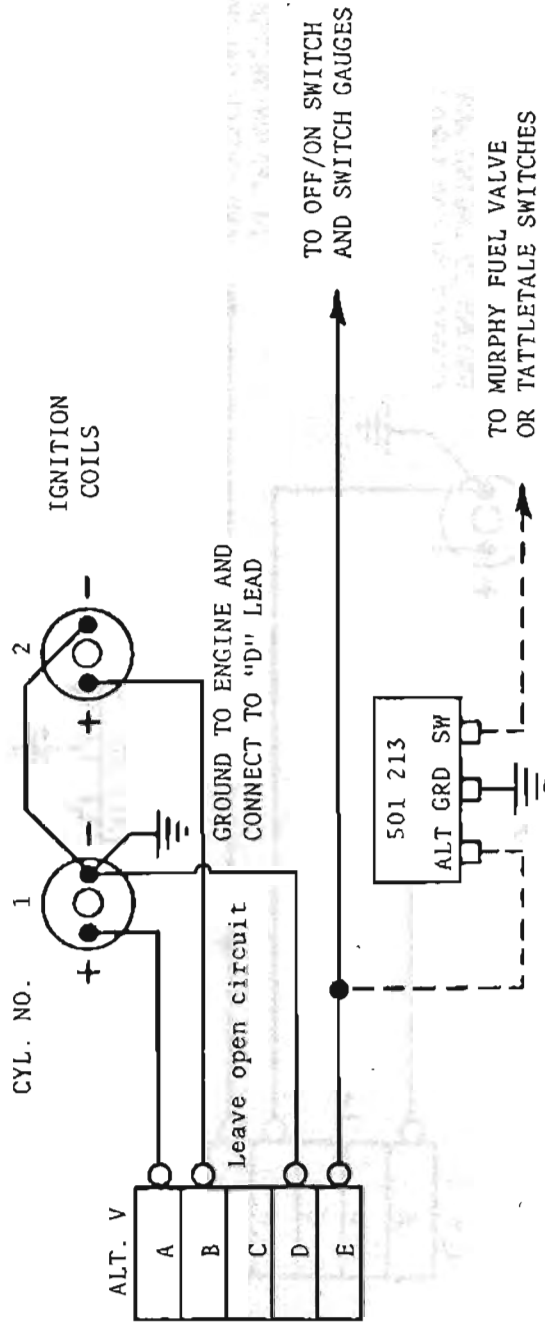

FIG. 2B

2-CYL., 2 PLUGS/CYL.
UNIT 2A28H

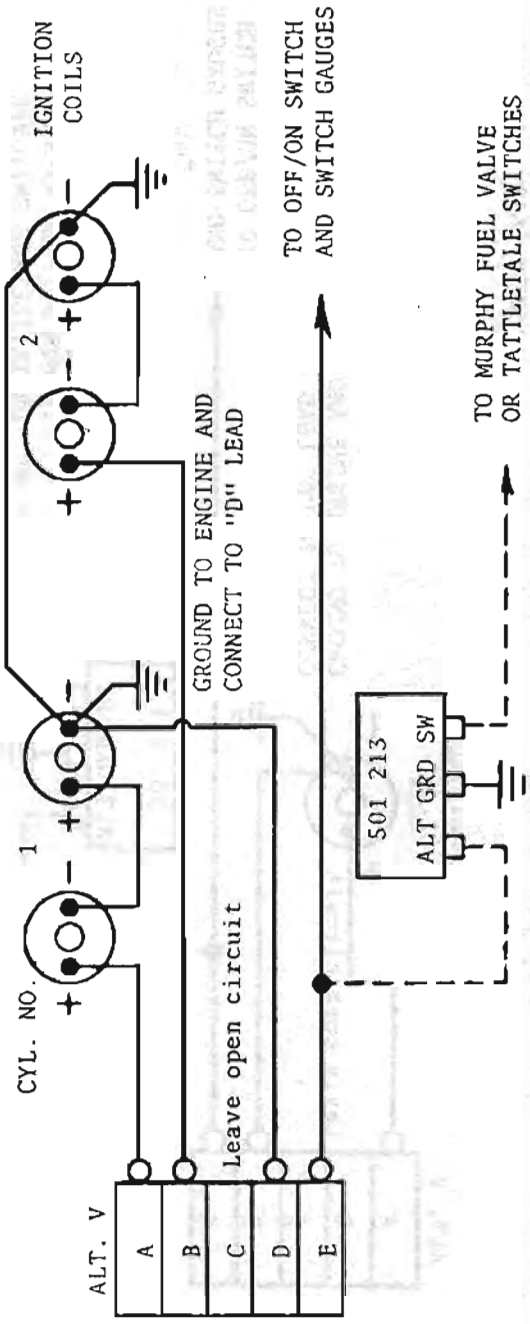

FIG. 3A

3-CYLINDER, 4-CYCLE
UNIT 3A14

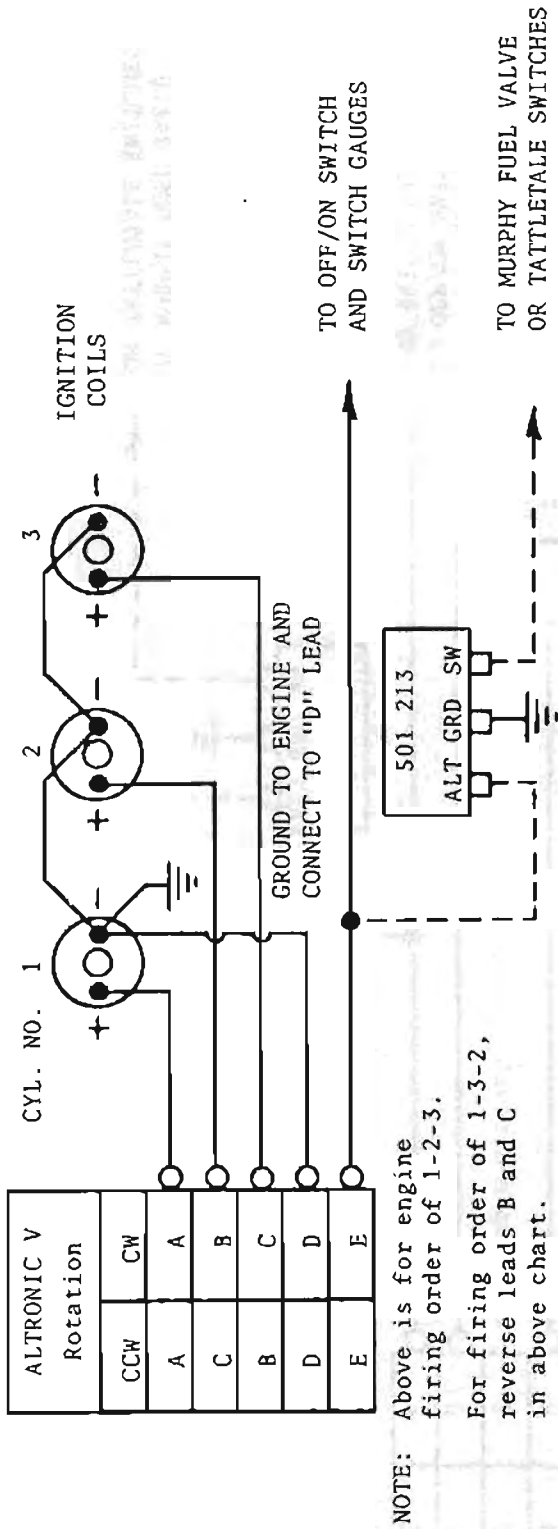
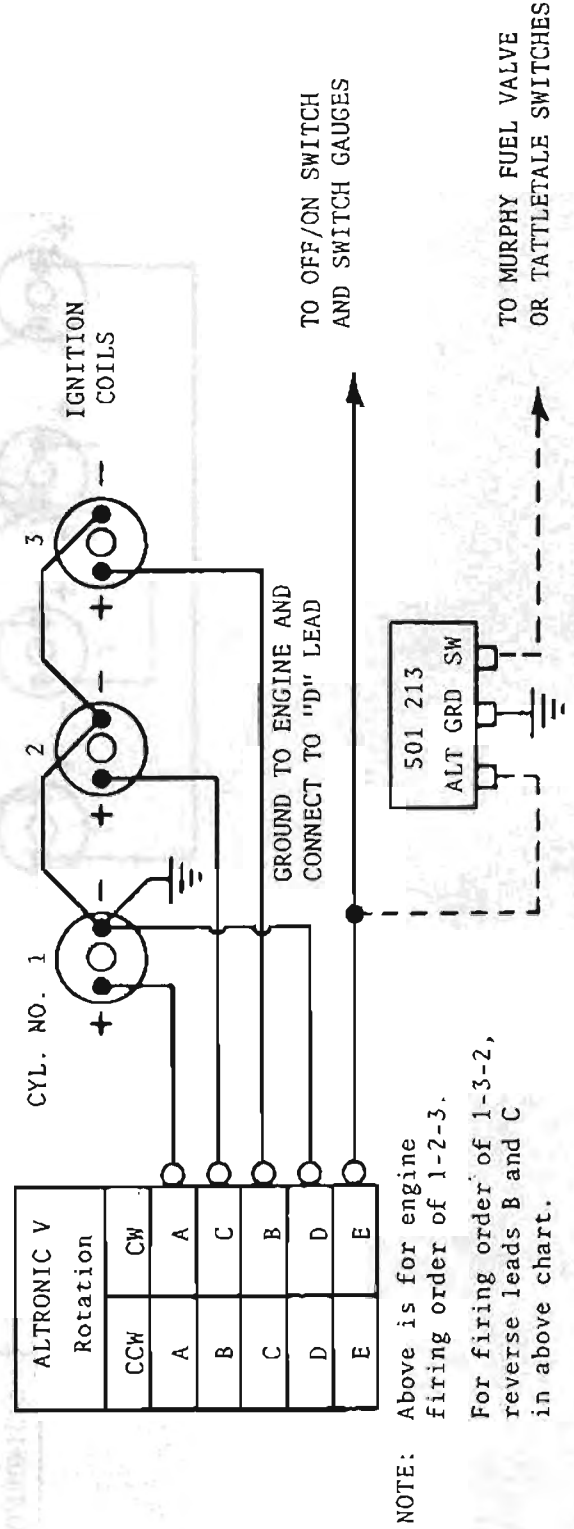

FIG. 3B

3-CYLINDER, 4-CYCLE
UNIT 3A25



4-CYL., 4-CYCLE
UNIT 2A14, 2A64

FIG. 4

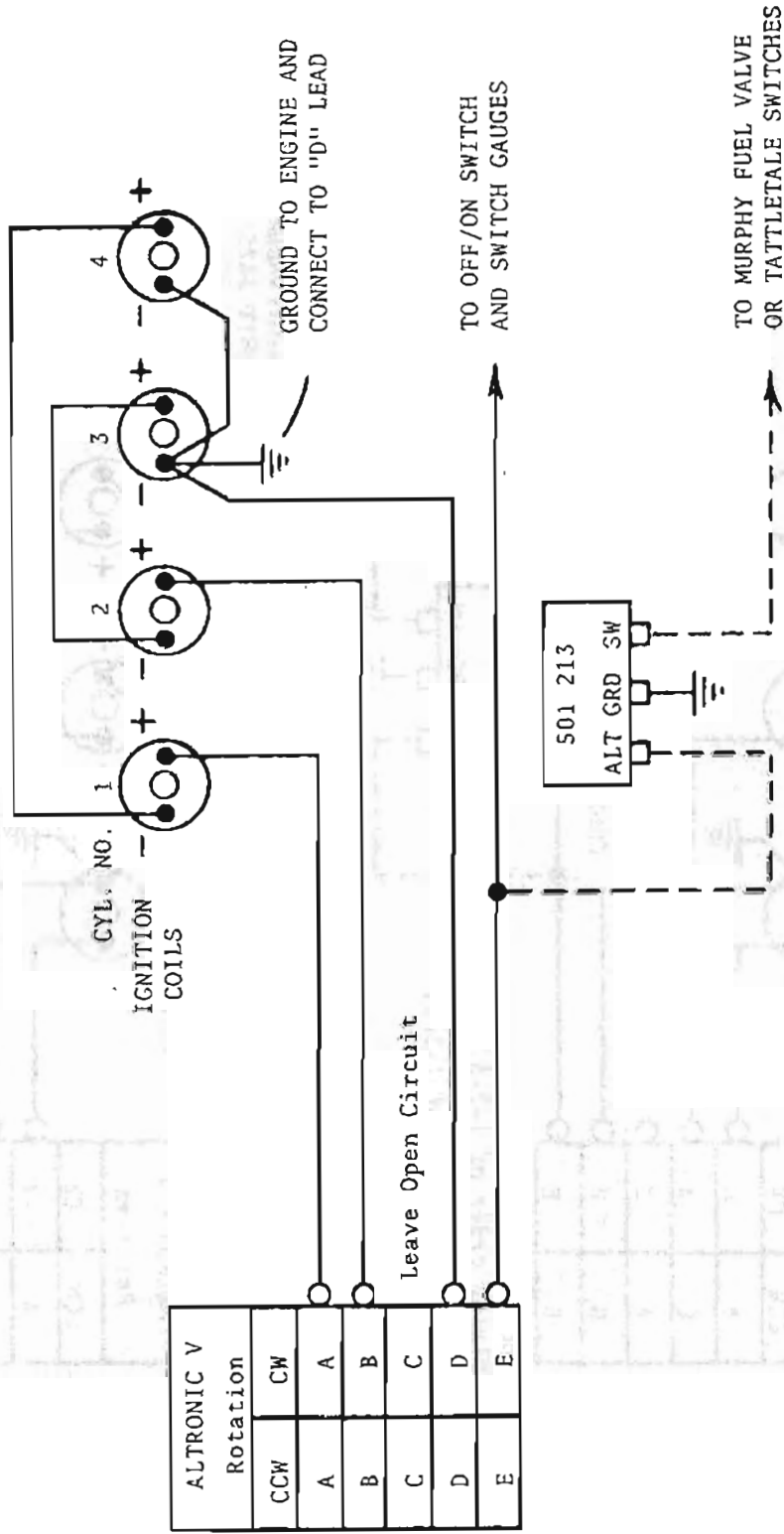
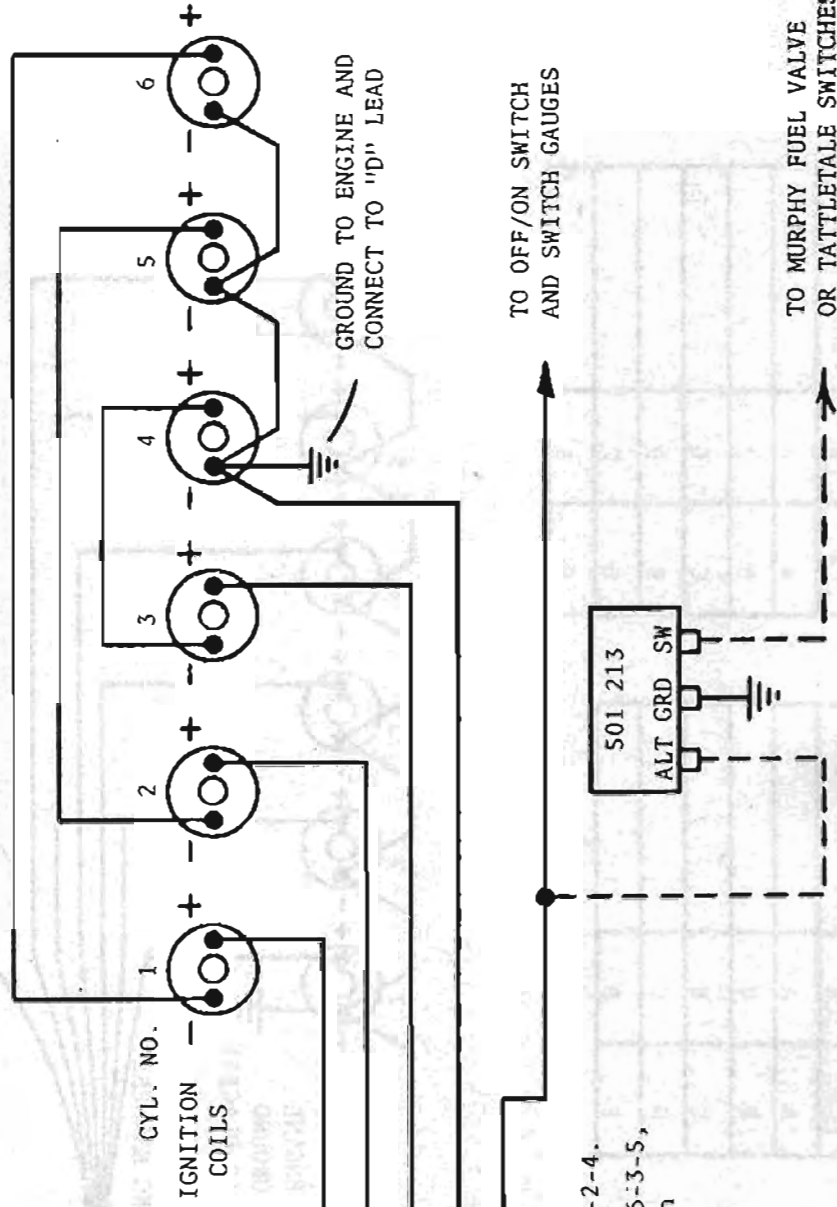

FIG. 5

6-CYL., 4-CYCLE
UNIT 3A14, 3A64



CYL. NO.
IGNITION
COILS

ALTRONIC V	
Rotation	
CCW	CW
A	A
B	C
C	B
D	D
E	E

NOTE: Above is for engine firing order of 1-5-3-6-2-4.
For firing order 1-4-2-6-3-5, reverse leads B and C in above chart.

FIG. 6

UNIT 4A24, 4A34, 5A24
6A24, 6A34

4-CYLINDER

IGN. ROTATION		ENGINE FIRING ORDER
CCW	CW	
A	A	
B	D	
C	C	
D	B	

5-CYLINDER

IGN. ROTATION		ENGINE FIRING ORDER
CCW	CW	
A	A	
B	E	
C	D	
D	C	
E	B	

6-CYLINDER

IGN. ROTATION		ENGINE FIRING ORDER
CCW	CW	
A	A	
B	F	
C	E	
D	D	
E	C	
F	B	

